

Cajun Injector®

Gas Fryer - Boiler - Steamer

Owner's Manual
Assembly, Care, Safety Instructions, and Recipes

Tool needed for assembly: Adjustable Wrench and Phillips Head Screwdriver

All Units are for Outdoor Use Only

Throughout this instruction manual, you will find important information required for the proper assembly and safe use of your new Cajun Injector gas fryer. Before assembling and using this appliance, read and follow all precautions, suggestions and instructions in this manual to avoid dangerous mistakes and to simply improve your enjoyment and experience with this appliance.

Keep this manual for future reference



By following these instructions, you will have a safe and enjoyable cooking experience. See page 14 for instructions on how to deep fry a turkey. If you feel that you need any additional assistance; or, if all listed parts are not included, Contact us first at toll free number: 1-800-229-9082.

- Pots not included with all models; check packaging for details
- LP Gas Cylinder Not Included

Bruce Foods Corporation
P.O. Drawer 1030
New Iberia, LA 70562-1030 U.S.A
www.cajuninjector.com

If you smell gas:

- Turn off gas flow to the appliance.
- Extinguish any open flame with a fire extinguisher.
- If odor continues, do not approach the appliance and immediately phone your Fire Department.
- DO NOT use this appliance within 25 feet (7.5 m) of flammable liquids.
- If a fire should occur, keep away from the appliance and immediately contact the local fire department. Do not attempt to extinguish an oil/grease fire with water.
- DO NOT use this appliance within 10 feet (3 m) of another gas cylinder.
- DO NOT leave this appliance unattended.
- NEVER overfill cooking container above maximum fill line.
- DO NOT allow the oil to surpass 400°F (200°C). If the temperature rises above 400°F (200°C) or if oil begins to smoke heavily, immediately shut off the burner or gas supply.
- Hot cooking oil (and many other cooking liquids) can remain dangerously hot for extended periods of time. Do not handle the cooking appliance until the cooking liquid has cooled below 115°F (45°C).
- DO NOT leave appliance unattended with an active flame. Oil can heat quickly and will ignite between 550°F to 700°F.
- Be cautious when in close proximity to any gas appliance. Falling or tripping near the gas fryer or over an appliance hose may result in the spilling or igniting of oil or splashing of boiling water, potentially causing personal injury and property damage.

FAILURE TO PROPERLY FOLLOW THESE INSTRUCTIONS OR WARNINGS MAY CAUSE FIRE OR EXPLOSION, WHICH COULD CAUSE PROPERTY DAMAGE, PERSONAL INJURY, OR DEATH.

COOKING WITH OIL OR GREASE:

- DO NOT overfill the cooking pot with oil/grease or water. Follow instructions in the manual for establishing proper oil/grease or water levels.
- DO NOT allow the oil to exceed 400°F (200°C); if this happens; adjust the regulator control knob in order to drop temperature. If oil temperature continues to rise or begins to smoke, IMMEDIATELY turn the burner OFF. Allow temperature to cool to 350°F (177°C) and then relight the burner, regulating the flame to maintain temperature.
- DO NOT leave appliance unattended while heating oil/grease or water, or while cooking food. Do Not allow other people or pets near a gas appliance while still hot after its use. High temperatures will remain long after appliance is turned off. Allow cooling below 115°F (45°C) before cleaning and storing.
- Unthawed and soggy foods may cause oil or grease to overflow. Always completely thaw and towel dry all foods before frying. If ice is present on the food, the thawing process is not complete and may cause liquid to boil over and splatter possibly causing a fire.
- Use the thermometer provided for proper temperature control when cooking with hot oil or grease.
- Use caution when placing food in the cooking vessel while the appliance is in operation. Carefully, watch for splashing or overflow of hot oil during emersion of product to be fried when placing in the gas fryer.
- When cooking with oil/grease, have an inspected, ready-to-use fire extinguisher readily accessible.

IF A GREASE OR OIL FIRE OCCURS:

In the event of an oil/grease fire, do not attempt to extinguish with water. A Type BC or ABC dry chemical fire extinguisher may in some cases contain the fire. If possible:

1. Turn off gas supply.
2. Wearing a protective glove, cover the pot with a lid.

If a fire occurs (outside the pot) follow these steps.

1. Call the Fire Department if property damage is possible.
2. Attempt to extinguish using chemical fire extinguisher as specified above.
3. Turn off the gas supply if possible.

In the event of rain, snow, hail, sleet or other form of precipitation while cooking with oil, cover the cooking vessel & immediately turn off the burner(s) and gas supply. DO NOT MOVE cooker stand or pot.

- DO NOT operate this appliance ON or UNDER any overhead roof covering (car port), as well on or under any awning, overhang, balcony, or deck.
- NEVER turn gas on indoors; only ignite this gas appliance outdoors. The gas fryer is not to be used in a building or any other enclosed area.
- Never place an empty cooking vessel on the gas appliance while in operation.
- DO NOT use IN or ON recreational vehicles and/or boats.
- This product is NOT designed for use as a heater and should never be used as one.
- Keep fuel supply hose away from the hot gas appliance while in operation.
- This product should always be a minimum 10 feet away from overhead construction, walls, or rails.
- Keep the cooking area adjacent to the gas fryer clear of debris and free of anything flammable or combustible.
- Use this appliance only on a level, stable, non-combustible surface like brick, concrete or dirt. Do not use appliance on or around any surface that will burn or melt such as wood decks, dry grass, leaves, wood rails, vinyl, or plastic. Asphalt surfaces may not be acceptable since they could be fire hazards.
- Accessory attachments and cookware not manufactured or supplied by Bruce Foods Corp. for this gas fryer are not recommended for use with this appliance.
- Never use this product for anything other than its intended purposes. This appliance is not designed nor intended for commercial use.
- Keep children and pets away from the appliance at all time.
- Never leave the appliance unattended.
- DO NOT move the appliance when it is in use. Allow the appliance to cool below 115°F (45°C) before moving or storing.
- Closed toed shoes should always be worn during operation of this appliance.
- DO NOT touch hot surfaces. Always wear protective gloves or mitts when removing the lid or basket from the cooking vessel.
- Prior to lighting the burner, check the wind direction and placement of the cylinder UPWIND and upright at least 20" away from the cooker stand.
- Use only a 20 pound cylinder or smaller with a protective collar.
- Always place the Cajun Injector® Gas Fryer in an open area with at least a 12 foot radius.
- Do not allow the hose to come in contact with any part of this appliance while in it is in use.

- Execute the gas leak test to detect gas leaks along hose or connection points prior to every use of this gas appliance.
- Avoid bumping of the appliance to prevent spillage or splashing.
- Always separate and detach your gas cylinder from burner apparatus when not in use.
- Keep your hands, hair and face away from the burner flame. DO NOT lean over the cooker when lighting the burner. This appliance has an open flame. Be careful of loose hair and clothing during operation.
- Never attach, detach or change out a gas cylinder; or move or alter fittings while the cooker is hot or in use.
- Never use a gas cylinder if it shows dents, gouges, bulges, fire damage, erosion, leakage, excessive rust, or other forms of visible external damage. The cylinder may be hazardous and should be checked before use by a propane supplier.
- When lighting your gas fryer, remove all unnecessary parts from cooker and its stand to prevent an explosion caused by gas build up.
- If burner does not ignite, turn off the regulator control valve, then close at cylinder and wait 5 minutes before trying to ignite it again. If the burner goes out during operation, first turn the regulator off, then shut off the valve at the gas cylinder.
- Do not allow anyone to conduct activities around your cooker during or following its use until the unit has cooled. The cooker is hot during operation and remains hot for a period of time following its use.
- Never drop food or accessories into hot liquids. Be careful when removing food from the oil or water; rest and allow the basket to drain all liquids since it and its contents are hot and could cause severe burns.
- When using your appliance, use caution when removing the basket from the pot to avoid pulling the pot off of your cooker stand.
- Never use glassware, plastic, or ceramic cookware on the appliance.
- When cooker use is complete, always turn the regulator control valve off first, then
- Shut off the gas cylinder valve.
- The use of alcohol, prescription or non prescription drugs may impair the consumer's ability to properly assemble or safely operate this gas appliance.
- Keep the ventilation opening(s) of the cylinder enclosure free and clear of debris.

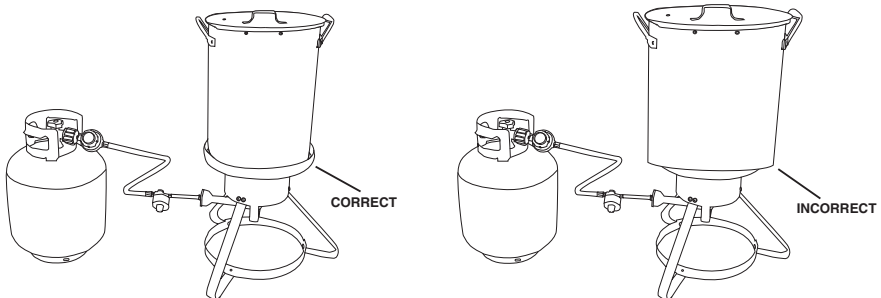

NEVER USE A COOKING POT OR VESSEL LARGER THAN 30 QUARTS. THE COOKING POT OR VESSEL MUST FIT INSIDE THE SECURITY RING OF THE COOKER

Gas Cylinder Storage, Placement and Filling:

- Do not store a spare LP-gas cylinder under or near appliance.
- Never fill the cylinder beyond 80 percent full. Over-filled cylinders can release gas.
- The gas cylinder safety relief valve may overheat, allowing gas to release causing an intense fire with risk of death or serious injury.
- If you smell, hear, or see gas escaping immediately move away from the gas cylinder and call the Fire Department for assistance. A fire causing death or serious injury may occur.
- Place a dust cap on cylinder valve outlet whenever the cylinder is not in use. The included dust cap should be the only dust cap applied to the cylinder valve outlet.
- Other caps or plugs may cause leaks.

Gas Cylinder Storage and Appliance Check:

- Cylinders must be stored outdoors, out of reach of children, and must not be stored in a building, garage, or any other enclosed area.
- Before each use check all nuts and bolts to be sure that they are tight and secure.
- Before each use inspect gas hose for any signs of damage.
- Before each use perform a soapy water test.

PARTS LIST

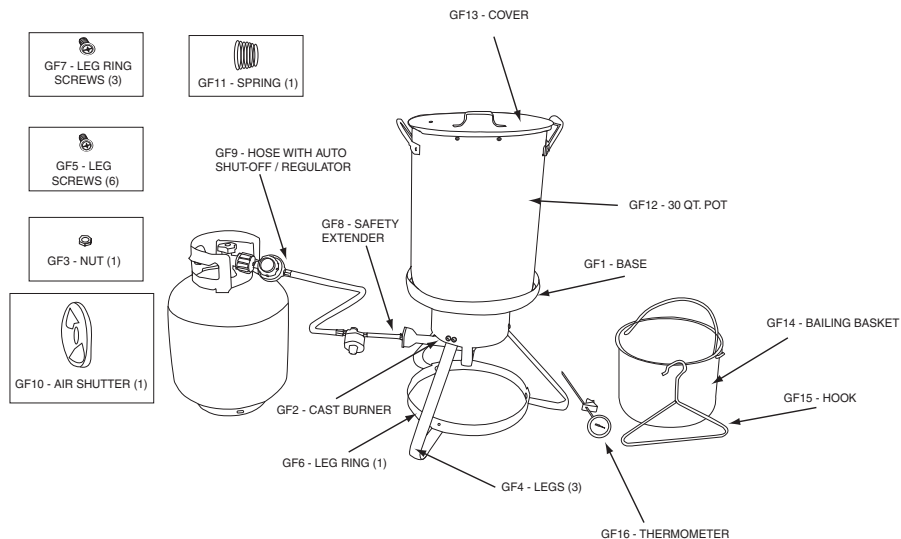

- GF1 - Base (1)
- GF2 - Cast Burner (1)
- GF3 - Nut (1)
- GF4 - Legs (3)
- GF5 - Leg Screws (6)
- GF6 - Leg Ring (1)
- GF7 - Leg Ring Screws (3)
- GF8 - Safety Extender (1)
- GF9 - Hose with Automatic Shut-off and Regulator (1)
- GF10 - Air Shutter (1)
- GF11 - Spring (1)
- GF12 - 30 qt. Pot (1)
- GF13 - Cover (1)
- GF14 - Bailing Basket (1)
- GF15 - Hook (1)
- GF16 - Thermometer (1)

ASSEMBLY INSTRUCTIONS

Tools needed: Adjustable Wrench and Phillips Head Screwdriver

Step 1 – Securing the Cast Burner to the Base (Burner Mount Bar)

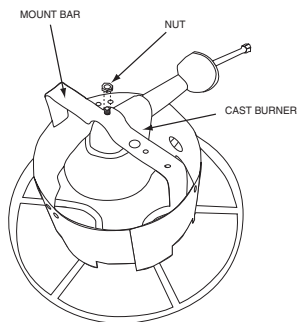

- Place base upside down on an even surface. The wider ring of the base should be facing downward.
- Locate the burner mount bar stretching across the narrower ring of the base.
- Remove the nut from the bottom of the cast burner.
- From the bottom side of the burner mount bar, place the cast burner into the groove in the center of the bar. The screw on the cast burner should fit into the hole in the center of the groove. The cast burner should be positioned towards the side of the base with the flame viewing hole.
- Fasten the cast burner screw securely to the burner mount bar with the nut.

Step 2 – Leg Assembly

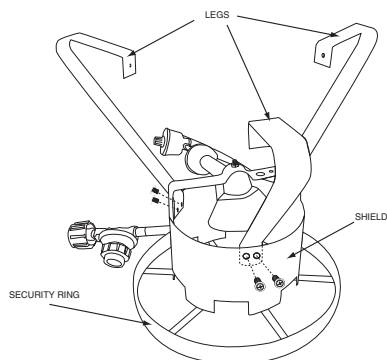

- Locate the end of each leg containing two holes.
- Join each leg to the inside of the narrower ring of the base so that the two holes of each leg are aligned with each set of two holes on the base. When in position, the legs should be projecting outward from the center of the base.
- Securely fasten each leg to the base with two screws per leg. The screws should be inserted from the outside towards the center of the ring.

Step 3 – Metal Base Ring Assembly

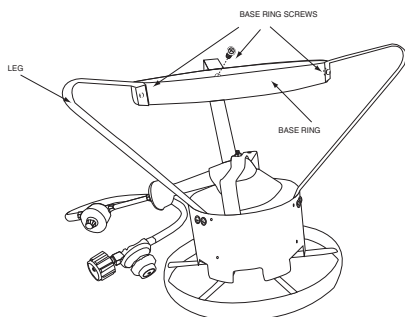

- Insert the metal base ring in between all three legs so that each of the three holes on the ring match up with each hole at the projecting end of the legs.
- Securely fasten the ring by inserting a screw into each hole and tightening. The screws should be inserted from the center of the ring outward.

ASSEMBLY INSTRUCTIONS

Tools needed: Adjustable Wrench and Phillips Head Screwdriver

Step 4 – Hose Assembly

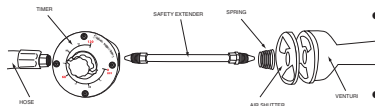

- Return the base to the upright position allowing the unit to stand on its newly assembled legs.
- Place the air shutter against the burner venturi so that it fits over it as a cap.
- Place the spring over the hole of the air shutter with the wide end of the spring on the air shutter.
- Attach the hose to the end of the safety extender without the swiveling nut by connecting the automatic shut-off timer to the projecting end of the safety extender; rotating clockwise until fastened securely. Insure that the automatic shut-off timer is facing upwards for easy viewing and operation.
- Insert the opposite side of the safety extender through the center of the narrow end of the spring and screw into the center of the air shutter and burner venturi until secure.

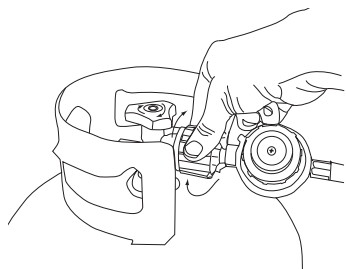

Step 5 – Regulator to Gas Cylinder Connection and Operation

- Before each use, perform a thorough inspection of the hose and all connecting parts. If it shows any indication of damage, replace all necessary parts before continuing with operation.
- **WARNING:** Any open flames must be extinguished before the hose can be connected to the gas cylinder.
- Insure that the regulator control valve is in the off position before it is connected to the gas cylinder. You are now ready to connect the regulator to the gas cylinder which is done by rotating the regulator clockwise onto the threaded opening of the cylinder until it is securely fastened.
- Slowly rotating the regulator valve clockwise will turn the flame on and steadily increase the flame. Slowly rotating the regulator valve counter-clockwise will steadily decrease the flame and turn the flame off.

Step 6 – Gas Leak Test

- Only propane gas is intended for use with this burner. Never use natural gas; the burner will not operate properly.
- Every time your burner is attached to a gas cylinder, the Gas Leak Test should be executed.
- Anything that can easily ignite, such as matches, lighters, sparks and lit cigarettes must be kept away from burner when performing the Gas Leak Test. Never use a flame to test for gas leaks.
- Never perform Gas Leak Test indoors. It must always take place outdoors in a well-ventilated area.
- All cookware must be removed from the cooker top before you perform the Gas Leak Test.

PROCEDURE:

- Remove all cookware from the cooker top.
- Rotate the gas cylinder valve counter-clockwise to the off position. Rotate the regulator control valve counter-clockwise to the off position.
- Combine 3 parts water with 1 part liquid dish soap. Mix well. Apply the mixed solution to the gas cylinder valve, the regulator control valve and down the entire length of the hose to the burner.
- Slowly rotate the gas cylinder valve clockwise to the on position and monitor the entire area of the gas cylinder valve for soap suds. **NEVER LEAVE GAS CYLINDER VALVE IN THE ON POSITION FOR MORE THAN 12 SECONDS.** If soap suds appear, rotate the gas cylinder valve counter-clockwise to the off position. To fix the leak, remove and replace the connection for proper fit. If the soap solution makes the area too slippery for a firm grip, clean the area with a damp cloth to eliminate the soap. Once corrected, reapply the soap solution and repeat the test.
- When the gas cylinder valve has passed the Gas Leak Test, rotate the regulator control valve clockwise to the on position and examine the area of the regulator control valve, down the entire length of the hose and up to the burner for soap suds. **NEVER LEAVE GAS CYLINDER VALVE IN THE ON POSITION FOR MORE THAN 12 SECONDS.** If soap suds appear, there is a gas leak in the area. If there is a leak in the area of a connection, it can be repaired by retightening the fitting. If there is a leak in the hose, the hose must be replaced before you can continue with operation. **DO NOT ATTEMPT TO PATCH THE HOSE.** Once the test is completed without any leaks, you can continue with use of your burner but you must wait a minimum of five minutes before igniting the burner.
- Cylinder is not included with appliance
- Never use a gas cylinder without a protective collar or larger than 20 lbs.
- If soap suds persist throughout any portion of the Gas Leak Test, terminate use immediately. For assistance with this malfunction, contact your propane dealer or Bruce Foods Corporation at 1-800-229-9082.

Step 7 – Lighting the Burner

- Insure that the regulator control valve is in the off position.
- Slowly rotate the gas cylinder valve clockwise to the on position.
- Using a special grill match or grill lighter for safety, insert a flame underneath the wind shield to the burner.
- Slowly rotate the regulator control valve to the on position until the burner ignites. If it takes more than five seconds for the burner to ignite, rotate the regulator control valve to the off position, then the cylinder valve to the off position and repeat the lighting process.
- **IN THE EVENT THAT THE FLAME IS EXTINGUISHED, DO NOT RELIGHT THE BURNER FOR FIVE MINUTES; THIS ALLOWS REMAINING FUMES TO CLEAR.**
- As soon as the flame is lit, rotate the regulator control valve clockwise until the flame rises. Rotate the air shutter, allowing more or less air to enter the cast burner until the flame becomes blue. Once the flame reaches appropriate color, adjust the flame with the regulator control valve to desired level.
- Using water or oil, whichever is required for the cooking method you choose; fill the pot to the Maximum Fill Line. NEVER fill the pot over the Maximum Fill Line to avoid any dangerous mishaps such as boil-over's.
- **DO NOT PLACE AN EMPTY POT ON A LIT BURNER. THIS WILL CAUSE SEVERE DAMAGE TO THE POT.**
- Rotating the regulator control valve clockwise and counter-clockwise will bring the contents of your pot to the desired temperature. Oil may ignite at a temperature of 400°F or higher therefore should never exceed temperatures of 350°F. To insure you maintain safe temperatures throughout the use of this burner, you must use a thermometer at all times. **IF THE BURNER BEGINS TO SMOKE, THE BURNER MUST BE SHUT OFF IMMEDIATELY.**
- Once you are through with this appliance, you must first rotate the regulator control valve counter-clockwise to reach the off position, and then rotate the gas cylinder valve counter-clockwise to reach the off position. All parts of the appliance, pot and left over contents must be allowed to completely cool before touching or handling for storage.
- **DO NOT REDUCE THE FLAME TO KEEP THE OIL WARM FOR LATER USE. THE TEMPERATURE WILL CONTINUE TO INCREASE AND POSSIBLY IGNITE IF THE BURNER IS NOT COMPLETELY TURNED OFF.**

Step 8 – Quick Drain System

- Locate the two hooks on the inside of the pot not far from the upper rim; these are the Quick Drain Hooks.
- Two oval shaped holes can be found on the basket: One is labeled “turkey” and the other is labeled “seafood”.
- The basket is able to hang from the hooks by slotting the Quick Drain Hooks through either one of the two oval shaped holes in the basket.
- When proper cooking time has elapsed, you are ready to drain the excess liquid from any food in the basket. While wearing protective frying gloves, use the included metal hook to lift the basket by the swiveling metal handle. Hang the basket from the Quick Drain Hooks by inserting the hooks into either the “turkey” hole or the “seafood” hole, depending on the type of food being cooked.
- Allow the food to drain for at least a few minutes or until you are positive that most of the excess liquid has fallen back into the pot. NEVER remove basket from fryer pot without first allowing the food to drain.
- The Quick Drain System can also be used to steam seafood. Place 6 inches of water at the bottom of the pot, hang the basket from the Quick Drain Hook labeled “Seafood,” and cover with the lid. Cooking times will vary depending on the type of food being steamed.

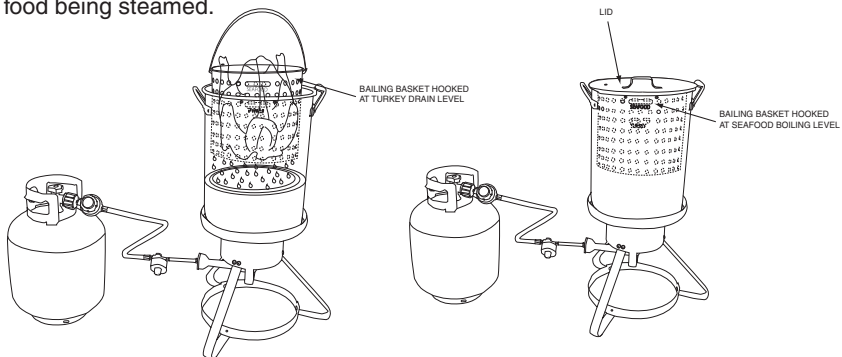

Step 9 – Drain Valve Operation (select models only)

- The drain valve, located near the bottom rim of the frying pot, allows you to safely and easily drain water/oil from the pot.
- BE SURE THAT ANY LIQUID INSIDE OF THE POT IS BELOW 100°F BEFORE DRAINING.
- Liquid should primarily be drained into a container before disposal.
- Place your desired reservoir directly under the drain valve nozzle; be sure that both the reservoir and the fryer are sturdy and not easily tilted.
- Turn the black switch on top of the drain valve nozzle 180° or until a steady flow of liquid is being dispersed from the nozzle into the reservoir.
- Close the valve by turning the switch to its original position once all of the liquid has drained.
- Some frying oils can be reused within a few days of being used; many people find the drain valve a useful mechanism to direct their frying oil back into its original container to be used at a later date.

Frying Non-Frozen Foods
(Oil may take up to 55 minutes to reach desired temperature)

Food	Maximum Quantity	Temperature	Time
French Fries	3 lbs. (1.36 kg)	400°F (204°C)	5-7 minutes
Fried Chicken	8 pieces	350°F (177°C)	14-18 minutes
Mushrooms	2 lbs. (0.91 kg)	325°F (163°C)	10-12 minutes
Fish Fillets	2 lbs. (0.91 kg)	400°F (204°C)	6-8 minutes
Whole Turkey	10-14 lbs. (4.5-6.4 kg)	400°F (204°C)	3 min. per lb. (0.45 kg) plus 5 minutes
Hot Wings	3 lbs. (1.36 kg)	400°F (204°C)	8-10 minutes

Frying Frozen Foods
(Refer to instructions on food packaging first)

Fried Okra	3 lbs. (1.36 kg)	400°F (204°C)	5-7 minutes
Chicken Nuggets	2 lbs. (0.91 kg)	375°F (191°C)	7-8 minutes
Mushrooms	2 lbs. (0.91 kg)	375°F (191°C)	8-9 minutes
Fish Sticks	2 lbs. (0.91 kg)	375°F (191°C)	6-7 minutes
Corn Dogs	10 lbs. (4.5 kg)	375°F (191°C)	See packaging
Cheese Sticks	2 lbs. (0.91 kg)	325°F (163°C)	See packaging

Boiling Non-Frozen Foods

Corn on the Cob	15-20 cobs	250°F (121°C)	5-8 minutes
Shrimp	10 lbs. (4.5 kg)	250°F (121°C)	3-4 minutes or until pink
Red Potatoes	10 lbs. (4.5 kg)	250°F (121°C)	25 minutes
Eggs	1 dozen	250°F (121°C)	10 minutes
Pasta Shells	3 lbs. (1.36 kg)	250°F (121°C)	until tender
Hot Dogs	50	250°F (121°C)	2-3 minutes

Steamed Foods
(Refer to instructions on food packaging first)

King Crab Legs	3 lbs. (1.36 kg)	250°F (121°C)	5-8 minutes
Clams/Mussels	10 lbs. (4.5 kg)	250°F (121°C)	5-7 minutes or until open
Yellow Squash with Red Peppers	2 lbs. (0.91 kg)	250°F (121°C)	steam until tender
Blue Crabs	10	250°F (121°C)	6-10 minutes
Lobster	1-4	250°F (121°C)	10-12 minutes

Do not place frozen poultry in oil. Use extreme caution when cooking frozen foods. Do not fill oil past fill line or exceed maximum amount of food in basket. Spillover can cause serious injury. Slowly lower basket into hot oil and cover with lid. Always wear protective gloves or mitts. Always pat dry moisture off the food pieces prior to frying.

When using the quick drain system, make sure that basket is firmly in place on rim of pot before releasing handle so basket will not fall back into hot oil or water.

Techniques for Successful Preparation of Fried Foods at Homes

Often when someone mentions frying foods at home, they are greeted with a chorus of negative comments ranging from messy, greasy, and dangerous to unhealthy. Utilizing the proper equipment and learning the correct methods and procedures, frying can overcome virtually all of these comments. No doubt, breading or battering foods and frying “in oil,” does add caloric content to foods. But, a sensible respect for portion sizes consumed and utilization of non-hydrogenated oil with zero trans fats greatly reduces the concern of “unhealthy” often expressed. Education in the proper procedures and techniques that should be employed when frying, greatly reduces the amount of oil absorbed by fried foods.

Frying Techniques and Temperature Control of the Cooking Oil

All forms of frying involve the cooking of food in oils or fats. Frying techniques vary depending on the frying vessel utilized (such as a wok utilized in stir-frying, a frying pan, or a deep fat fryer); the amount of fats or oils required (from sautéing or stir frying to pan frying to deep fat frying); cooking temperature; and preparation methods employed with foods for frying. For the purposes of this pamphlet, we'll concentrate on pan frying, deep fat frying, and mention a baking misnomer, oven frying, which is actually a form of baking.

Frying is classified as a form of dry-heat cooking since water is not utilized to transfer heat to the food being cooked. Instead, the heat in the oil is transferred to the water in the food so that the moisture in the food turns to steam to cook the food from the inside out. Whatever form of frying employed balances the realities of time, temperature, and the surface area of food in contact with the oil, plus the food's structure and moisture. Often this means assuring that the food is fully cooked in the interior before being burned on the exterior. As an example experts recommend pan-frying nothing thicker than 1-inch as the exterior is likely to burn before the inside is fully cooked.

Maintaining proper oil temperature is absolutely crucial to all forms of fried foods. Recommended oil temperature ranges from 350°F – 375°F with a target temperature of 365°F. And virtually all frying tips seek to assist you in maintaining correct oil temperature. Hot oil causes the food's internal moisture to turn into steam that keeps the oil out while the hot oil also keeps the moisture in (especially when a batter or breading barrier is used around the surface area of the food forming a crunchy, brown crust). If the oil is too hot, the steam reduces the moisture content and overcooks the food. On the other hand, if the oil temperature is too low, a lack of steam allows the oil to penetrate deep into the crust producing oily, unappetizing fried food. The oil must be hot enough to quickly seal the surface of the food, but not too hot to burn the outside before the inside is completely cooked. Done correctly at a proper temperature, only a minimal amount of oil is absorbed into the food.

Pan Frying

This form of frying is characterized by the use of significantly less hot oil where food is semi-submerged in hot oil in an electric skillet or in a fry pan over an open flame. When pan-frying, the oil's depth should be no more than 1/2 the thickness of the food. Pan frying differs from deep frying since the food touches the bottom of the pan and the exposed top side of the food allows some loss of moisture in the food as it cooks.

The advantage of pan frying is the use of less oil, this is also a disadvantage as it is more difficult to maintain temperature of the oil. The moisture loss and faster browning of pan fried foods can be advantageous or detrimental depending on the choice of foods to be pan fried. The best candidates for pan frying include fish, shellfish, tender meats and vegetables. Foods to be pan fried are generally covered with a batter or breading and have a rich texture that contrasts with the crispy, crunchy outside.

When pan-frying use an electric skillet with a thermostat to control oil temperature if possible. Otherwise, some experimentation may be required to control oil temperature. When oil temperature is reached, add the food to the pan; and fry on one side until brown. Using tongs or a spatula (never a fork) turn and brown the second side realizing that the second side generally takes less time (it's hotter when turned over than the first side was) to cook. As with all forms of frying, never crowd the pan as this can dramatically reduce oil temperature. Recovery time is the duration of time necessary to return the oil to the desired cooking temperature. When cooked too long, food will likely be greasy without the seared crunchy exterior most people desire from fried foods.

Oven Frying

Oven frying produces a result that is healthier (usually less oil yet similar to fried foods even though it isn't a real frying process. Generally food is baked in a hot oven and basted once with a small quantity of fat or cooking spray. As with deep-fried foods, most foods are breaded or battered prior to being baked to seal in the juices and produce a crunchy, crispy crust. Food normally does not require turning and cooks quickly using this high heat (450° – 500°F) method. This works especially well with fish fillets, chicken pieces and pork chops. Generally bread crumbs or corn flake crumbs are utilized to produce a crispy crust when oven-frying.

The Basics of Frying:

1. Recommended Products : A quality candy or deep-frying thermometer. A deep fat frying thermometer, preferably with a clip that allows the thermometer to be affixed to the side of the frying vessel is essential, since accurate control of the temperature of the frying oil is essential to successfully fried foods.
2. An Electric Skillet is preferred for pan frying; otherwise, choose a pan with a thick heavy bottom that is larger in circumference than the heat source (this will prevent oil from dripping down the exterior of the pan into an open flame that might cause a fire.) Use a heavy skillet or frying pan that is wider than it is deep and has a heavy bottom to help regulate uniform heat from the bottom of the pan. This is absolutely essential when pan frying with limited amounts of oil.
3. A Cajun Injector Electric Fryer for deep fat frying with digital timer and thermometer, basket, clear cover, and petcock drain spout specifically designed for high heat frying of large items such as turkey as well other deep fried foods.

Deep Frying

Foods to be deep-fried should be of a size and shape that permits individual pieces to float freely in the fat. The fat should surround the food and begin cooking it on all sides at once. The food is usually battered or breaded to protect the food's surface moisture from coming into contact with the hot oil creating an exterior layer or crust sealing food flavors and juices inside. We suggest the following tips:

1. Use a pan wider than it is deep, and that is wider than the heat source (so oil won't come in contact with direct heat.) Always use clean, fresh oil or previously used oil, properly filtered and refreshed by frying a raw potato or handful of parsley for about five minutes prior to frying food for dinner. Delicate foods should not be fried in oil previously used to fry strongly flavored foods.
2. Much of fried food odors can be absorbed by placing a small cup of bleach nearby. Be sure to mark as "Bleach" and keep children away from the cup as well as from the hot oil.
3. Never fill your fryer more than half full of oil. You will need a minimum of three inches between the oil surface and the top of the pot.
4. Constantly monitor temperature of the oil. Never crowd the frying oil, fry in small batches. The oil should freely bubble around each piece of food at correct temperature.
5. Use proper tools when removing fried foods and draining oils to a plate with several layers of paper towels. To add more absorbency, place a brown paper bag below the paper towels on the plate.
6. Keep deep-fried foods warm by placing in a single layer on fresh paper towels (after initial draining step above is finished) in a 250°F oven while you complete frying.

Choice of Oil or Fat as a Frying Medium:

1. Your choice of Oil or Fat often depends on the frying technique to be utilized and the projected frying temperature. As an example, when sautéing, oil choice often depends on the flavor to be imparted as butter or bacon grease are often employed. Olive oil is also a good choice if temperatures not over 300°F are to be employed in sautéing or pan-frying.
2. Health Concerns can determine your choice. We recommend non-hydrogenated oils with zero trans fats and zero cholesterol. This eliminates the use of animal fats.
3. Smoke point is a stage at which fat or oil begins to smoke. Utilize oils with a high smoking point (above 400°F) and high stability. Most vegetable oils have smoking points over 400°F and can be used in all cooking methods.
4. High heat, water, and burned food particles break the oil down over time. Filter the oil after use. Allow the oil to cool after use and filter to remove all food particles that could burn during reuse.
5. Replace your old oil if you notice the following symptoms: Excessive smoking at normal temperatures; strong oil discoloration; rancid odor.

Choice of Coating Mix, Breading Mix, or Batter Mix:

A breaded item is any food that is coated with bread crumbs, cracker meal, corn meal, or other dry meal to protect it during cooking. Breaded foods can be seasoned, marinated, or rubbed prior to breading, or seasonings may be added to the flour, crumbs, or meal, before the coatings are applied. Coating batters are liquid or semiliquid mixtures, utilizing flour, milk, and eggs, used in cooking.

1. When breading meats, chefs call a three-step process “the standard breading procedure.” First, pat the food dry (always reduce moisture as much as possible to reduce splattering and oil degradation) and then dredge in seasoned flour. The flour adds seasoning and allows egg wash to adhere. Next dip the floured food in an egg wash (egg wash should contain whole eggs whisked together with approximately one tablespoon of milk or water per egg.) Egg wash will cause the breading to coat the item and form a tight seal when food is cooked. Lastly, coat the food with crumbs or seasoned meal, shake off the excess and place in a container in a single layer.
2. Battering. Prepare the batter according to directions. Pat the food dry, dredge in seasoned flour, if desired. Dip the item in the batter and generally cook immediately. There are some chefs that recommend chilling the batter with ice or refrigeration to obtain a great sear and those who recommend battering by placing in a single layer and refrigerating for up to 30 minutes to dry the batter. When using these methods, be sure to cook very small batches so as to maintain oil temperature.

For Gulf Coast Style Seafood Boil

5 lbs. Shrimp * 8 Medium Crabs * 4 lbs. Crawfish * Vegetables

1. Wash Shrimp or seafood in cold water. Confirm crabs and crawfish are alive prior to boiling (crabs and crawfish should be alive at time of cooking). Purge Crawfish in salted water.
2. Place products to be boiled inside the basket. Be sure that water displacement does not exceed the capacity of the boiling pot. This can be checked by placing all the ingredients in the pot and placing the basket in the cold water (prior to heating) to be sure that the boiler will not overflow the pot.
3. Measure out water (not to exceed 3-gallons) following the instructions on your favorite seafood boil package. For a spicier boil, add 1 12-oz. bottle of The "Original" Louisiana Brand Hot Sauce per package of spice mix used. Bring to a boil. Add boil mix contents, for mildly seasoned, non-messy food or for spicy, hot cooked seafood or vegetables, reserve 2 Tbsp. spice mix per package for sprinkling over seafood or vegetables (after draining and prior to eating).
4. First add favorite selected vegetables (optional step) such as small white or red potatoes, mushrooms, corn, garlic pods, lemon slices and small onions to the boiling mixture. Hard simmer in boiling solution for 10 minutes or until vegetables are cooked. Cut heat and allow to soak in mixture for 10 minutes. Remove vegetables. Return solution to a boil. Add Seafood; return to boil, timing shrimp 3-minutes; Crabs or Crawfish 8-10 minutes depending on size.
5. Remove from heat. Add ice to stop cook (being sure not to overflow the boiling pot) and allow to soak for 10-15 minutes prior to draining and pouring out of container. Sprinkle reserved spicy boil mix over boiled seafood prior to eating.
6. To double the amount being boiled: Add an additional 1-1/2 gallons Water (Total 3-Gallons) along with an additional 1/3 cup of Salt; 1/2 cup of Red Cayenne Pepper, and an additional 12-oz. bottle "Original" Louisiana Brand Hot Sauce to the directions given above.

Chesapeake Style Steamed Crabs or Seafood

Crabs * Crawfish * Fish * Vegetables

1. Utilize a boiling pot with a raised rack a minimum of 2-3 inches above the bottom of the boiling pot. Add equal amounts of water and vinegar to a water level just below the rack. Optional: Add a bottle of 12-oz. "Original" Louisiana Brand Hot Sauce to the water-vinegar mixture.
2. Layer Crabs or other foods to be steamed. Sprinkle your favorite spice mix lightly, or until partially covered, and steam in covered pot until crabs turn red, or other foods are fully steam cooked.

Injectable Marinade Concepts and Utilization Techniques

Injectable marinades and brines possess the same characteristics as their counterparts except that they do not require product soaking in order to impart flavor; moisturize, and tenderize. Unlike marinade soaking methodologies that only penetrate about a 1/4 inch into meat surfaces, require long soak times, and contaminate expensive marinades, flavor injection infuses blended flavors deep inside the meat. Conceptually the flavor injection concept makes good sense: instant flavor, yet no waiting, no waste as marinade is injected, and no fats are required in the marinades to protect the meat surface during soaking time. Rubs, seasonings, and sauces are used to flavor the surface of the meat.

As with many culinary skills, proper technique when “flavor injecting” will result in superior results. The flavoring should be spread uniformly throughout the meat with as few punctures of the meat as possible. The flavor injector is a syringe with a needle attached to a plunger which allows the user to inject the flavoring deep into the meat.

Injecting Tips for poultry start with limiting the puncture holes and when possible separating the skin from the meat and puncturing directly into the geometric center of the meat. Carefully and slowly inject along the grain of the meat aiming the injector into the middle of the meat and reduce plunger pressure on liquid as the needle comes nearer the surface of the meat (so meat can close up behind the needle.) Do not pull the needle completely out of the puncture hole unless to reload with liquid. Use the same hole to angle into the other areas of the meat, slowing infusing flavor as the needle moves back toward the meat surface. Remember the object is to spread your injection pattern so as to get small amounts of flavor in as many places as possible. Occasionally, some of the liquid is likely to spurt out on the meat surface. Rub the flavoring over the surface of the meat and then rub and season the surface of the meat as desired.

Injecting Techniques



1. Attach injector needle by turning clock-wise until snug. Do not over tighten. Hint: Be sure rubber plunger is lightly coated with oil prior to using. Determine amount of marinade required (1.5 to 2 ounces per pound of meat) and measure out contents into a clean container to prevent contamination of unused marinade.

2. Pull plunger to draw marinade into injector. Hint: Both slots in needle should be immersed in liquid to prevent air from entering injector chamber.

3. For best results, a geometrically centered injection point should include one deep and straight needle track as well as two additional tracks at approximately 45 degree angles branching out from the original injection point. (See illustration 1A)

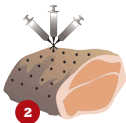
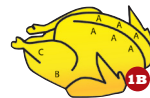

4. Once inserted deep into meat, press plunger down while slowly pulling injector needle out of meat to ensure even distribution of marinade. Follow same procedure with each needle track at each insertion point.

5. See illustration 1B for suggested insertion points for turkey.

6. See illustration 2 for suggested insertion points for roast.

Cajun Injector® Deep Fried Turkey

Prep Time: 20 minutes

Cook Time: 35-45 Minutes

Yield: 8 servings

Ingredients:

- 1 Cajun Injector® Propane Fryer
- 3 Gallons Cajun Injector® Cottonseed Oil
- 1 10 - 12 Pound Whole Turkey
- 2 16 oz. jars Cajun Injector® Creole Butter Recipe Marinade
- 1 8 oz. canister Cajun Injector® Quick Shake® Cajun Shake®

Method:

Place the outdoor gas burner on level dirt or grassy area. Never fry a turkey indoors, in a garage, or in any structure attached to a building. Do not fry on wood decks, which could catch fire, or concrete, which could be stained by the oil, (have a fire extinguisher nearby for added safety). Add oil to a 7 to 10 gallon pot with a basket. At medium-high setting, heat the oil to 350°F (depending on the amount of oil, outside temperature and wind conditions, this should take about 20 to 40 minutes). Remove the giblets and neck from the turkey. Cut off the wing tips and plump little tail as they may get caught in the fryer basket. Rinse the turkey well with cold water, and pat dry thoroughly with paper towels. Take care to dry inside the cavity. Place in a large pan and inject with 2 ounce per pound of Cajun Injector Creole Butter Recipe Marinade. Season liberally inside and out with Cajun Injector Quick Shake Cajun Shake. To allow for good oil circulation through the cavity, do not truss or tie legs together. Place the turkey in basket, neck down. When the deep-fry thermometer reaches 350°F slowly lower the turkey into the hot oil. The level of the oil will rise due to the frothing caused by the moisture from the turkey but will stabilize in about 1 minute, (to prevent burns from the splattering oil wear oven mitts/gloves, long sleeves, heavy shoes, and even glasses. It is wise to have 2 people lowering and raising the turkey). Immediately check the oil temperature, and increase the flame so the oil temperature is maintained at 350°F. If the temperature drops to 340°F or below, oil will begin to seep into turkey. Fry about 3-1/2 minutes per pound, or about 35 to 45 minutes for a 10 to 12 pound turkey. Stay with the cooker at all times, as the heat must be regulated. When cooked to 170°F in the breast or 180°F in the thigh, carefully remove the turkey for the hot oil. Allow the turkey to drain for a few minutes. Remove the turkey to a cutting board and cover with foil. Let it rest for 20 minutes. Slice the turkey and serve hot.

Original Louisiana Habanero Fried Chicken

Prep time: 20 minutes

Marinate time: 4 hours

Cook time: 30 minutes

Yield: 8 servings

Ingredients:

	Cajun Injector® Cottonseed oil, for deep-frying
1	Quart Buttermilk, Plus 2 Cups
2 tbsps.	Cajun Injector® Quick Shake® Cajun Shake® seasoning
2 tbsps.	Louisiana Brand Hot Sauce
2 tsps.	Louisiana Brand Habanero Sauce
2	Chicken (3 to 4 pounds each), Each Cut Up Into 8 Pieces
4 cups	All-Purpose Flour
1 tsp.	Garlic Powder
1 tsp.	Onion Powder
1 tsp.	Sweet Paprika
2 tsps.	Cayenne Pepper

Method:

In a large bowl or baking dish, whisk together 1 quart of the buttermilk, Cajun Injector® Quick Shake® Cajun Shake® seasoning, and 2 Tablespoons Louisiana Brand Hot Sauce. Add the chicken pieces, turn to coat, cover, and refrigerate for at least 4 hours or overnight. Preheat oil to 400°F in electric fryer, or 350°F in propane fryer. Place the remaining 2 cups of buttermilk and 2 teaspoons Louisiana Brand \$ Hot Sauce in a bowl. Stir together the flour, garlic and onion powders, paprika, and 2 teaspoons cayenne pepper in a large bowl. Divide flour mixture among 2 shallow platters and season generously Cajun Injector Quick Shake Cajun Shake. Drain the chicken in a colander and pat it dry. Dredge the pieces a few at a time in the flour mixture and pat off excess, then dip in the buttermilk and allow excess to drain off. Dredge in the second plate of flour, and pat off the excess. Put the chicken pieces on a piece of waxed paper, or on a clean platter while you heat the oil. Working in batches, add the chicken pieces to the hot oil, 4 or 8 at a time and fry, turning the pieces occasionally, until evenly golden brown and cooked through, about 20 minutes. Remove from the oil with a slotted spoon and transfer to a rack to drain. Repeat to cook the remaining pieces. Serve hot.

Beer Batter Shrimp

Prep time: 10 minutes

Cook time: 5 minutes

Yield: N/A

Ingredients:

3	Eggs
3 cups	Flour
1 tsp.	Baking Powder
12 oz.	Favorite Beer
	Cajun Injector® Quick Shake® Cajun Shake®

Method:

Preheat oil for deep frying to 350°F. In mixing bowl beat eggs gently. Add flour and beer gradually until batter is a little thicker than pancake batter. Mix in baking powder. Dredge shrimp, fish, or vegetables through batter. Shake off excess, and fry at 350°F until golden brown.

Cajun Injector® Fried Catfish

Prep time: 10-15 minutes

Cook time: 3-5 minutes

Yield: 3-4 lbs. of fish

Ingredients:

Cajun Injector® Cottonseed Oil

1 package Cajun Injector® Seasoned Fish Fry Mix

Method:

Preheat oil to 350°F. Dip Fish into a bowl of cold water. Shake off excess water. Roll Fish in 10 ounces of the Cajun Injector Seasoned Fish Fry Mix. Deep fry at 350°F until golden brown.

Cajun Injector® Hushpuppies

Prep time: 10-15 minutes

Cook time: 3-5 minutes

Yield: 16-18 hushpuppies

Ingredients:

Cajun Injector® Cottonseed Oil

1 package Cajun Injector® Hushpuppy Cornbread Mix

1 egg

1/4 cup of milk

Method:

Preheat oil to 350°F. Combine 8 ounces of the Cajun Injector Hushpuppy Cornbread Mix, 1 egg and 1/4 cup of milk in bowl. Mix until smooth. Let batter stand for 30 minutes to thicken. Drop batter by tablespoon or scoop into hot oil. Deep fry at 350°F until golden brown.

Chicken Fried Venison Steak

Prep Time: 10 minutes

Cook Time: 15 Minutes

Marinade Time: 1-2 hours

Yield: 4 servings

Ingredients:

Cajun Injector® Cottonseed Oil

1 - 10 oz. Packet of Cajun Injector® Chicken Fry Mix

4 - 4 oz. Venison Cubed Steaks

Method:

Preheat oil to 400°F in electric fryer, or 350°F in propane fryer. Heat enough oil for deep frying to 350°F. Mix 6 tablespoons of Cajun Injector Chicken Fry Mix with 3/4 cup of water and mix until smooth. Dip steaks into batter then roll in remaining dry chicken mix until coated. Deep fry the coated steaks at 350°F until golden brown.

Louisiana Wildly Wicked Buffalo Catfish Wrap

Prep Time: 10 minutes

Cook Time: 7 minutes

Yield: 5 wraps

Ingredients:

1 lb. Catfish Fillets (USA raised)
1 (8 oz.) bag Cajun Injector® Chicken Fry Mix
1 Diced Tomato
1/2 cup Louisiana Brand Wildly Wicked Wing Sauce
1 Package (8 inch) Flour Tortillas
1 lb. Cole Slaw (recipe follows)
2 cups Cottonseed Oil, for Frying

Method:

Preheat oil to 400°F in electric fryer, or 350°F in propane fryer. Cut catfish fillets chicken into strips about 1/2"- 3/4" wide and batter according to the directions on the chicken fry bag. Fry until golden brown, remove, and drain on paper towels. Toss catfish strip in wing sauce to coat evenly. Heat tortillas in an oven or microwave until warm and pliable. Assemble the wrap by adding coleslaw, catfish strips, and diced tomatoes.

Cole Slaw

Prep Time: 10 minutes

Cook Time: N/A

Ingredients:

8 oz. Mayonnaise
4 oz. Sour Cream
2 oz. Sugar
1 oz. Apple Cider Vinegar
1 Clove Minced Garlic
1 lb. Cole Slaw Mix

Method:

Mix mayo, sour cream, sugar, vinegar, and garlic together in mixing bowl, add the mixture to the slaw and mix well.

Louisiana Wildly Wicked Turkey Tenders

Prep Time: 10 minutes

Cook Time: 10 Minutes

Yield: 4-6 servings

Ingredients:

1	10 oz. packet of Cajun Injector® Chicken Fry Mix
2	Turkey Breast Boneless Skinless Cut into Strips
1/2 cup	Louisiana Brand Wildly Wicked Wing Sauce
1/4 cup	Melted butter
2 tbsps.	Original Louisiana Brand Hot Sauce
	Cajun Injector® Cottonseed Oil

Method:

Preheat oil to 400°F in electric fryer, or 350°F in propane fryer. Heat enough oil for deep frying to 350°F. Mix 6 tablespoons of Fry mix with 3/4 cup of water and mix until smooth. Dip turkey strips into batter then roll in remaining dry chicken mix until coated. Deep fry the coated tenders at 350°F until golden brown. While turkey is cooking melt butter and mix with wing sauce. When turkey is cooked remove from oil place in bowl and cover with wing sauce and butter mixture, toss to coat well.

Bruce's® Tempura Battered Smoked Soft-shell Crab

Prep time: 10 minutes

Cook time: 35 minutes

Yield: 6 crabs

Ingredients:

6	Soft-shell Crabs
2	Packages Bruce's® Sweet Potato Pancake Mix
1 cup	Seltzer Water
	Cajun Injector® Quick Shake® Cajun Shake®
1 qt.	Cottonseed Oil for Frying

Method:

Smoke the softshell crab for 30 minutes at 165°F degrees with pecan wood pelletes. In a mixing bowl, combine pancake mix and seltzer water to make a batter. Carefully dip the crab into the batter and fry at 350°F or until golden brown. Drain on paper towels and serve with Cajun cole slaw.

Cajun King® Country Fried Quail

Prep Time: 10 minutes

Cook Time: 15 Minutes

Yield: 4 servings

Ingredients:

Cajun Injector® Cottonseed Oil
3 Large Eggs
1/4 cup Milk
1 tbsp. "Original" Louisiana Brand Hot Sauce
1 bag Cajun Injector® Chicken Fry Mix
2 tbsp. Cajun King® Blended Spice Mix
4 Quail, cleaned and cut in half

Method:

Preheat oil to 400°F in electric fryer, or 350°F in propane fryer. Heat enough cottonseed oil for deep frying to 350°F. Beat eggs and milk together, and add hot sauce. Combine fry mix and blended spice mix. Dredge the quail in the egg mixture then in the fry mix, knock off excess coating and deep fry until golden brown.

Cajun Injector® Chicken Fried Caribou Steak

Prep Time: 10 minutes

Cook Time: 15 Minutes

Marinade Time: 1-2 hours

Yield: 4 servings

Ingredients:

4 (4 oz.) Caribou Cubed Steaks
1 (16 oz.) jar Cajun Injector® Creole Butter Recipe Marinade
1 (10 oz.) packet of Cajun Injector® Chicken Fry Mix
1 tbsp. Cajun Injector® Quick Shake® Cajun Shake®
2 tbsps. "Original" Louisiana Brand Hot Sauce
Cajun Injector® Cottonseed Oil

Method:

Preheat oil to 400°F in electric fryer, or 350°F in propane fryer. Heat enough oil for deep frying to 350° F. Mix 6 tablespoons of Fry mix with 3/4 cup of water and mix until smooth. Dip steaks into batter then roll in remaining dry chicken mix until coated. Deep fry the coated steaks at 350° F until golden brown.

Louisiana Wildly Wicked Buffalo Wings

Prep Time: 10 minutes

Cook Time: 10-15 minutes

Yield: 1 lb.

Ingredients:

Cajun Injector® Cottonseed Oil
1 lb. Chicken Wings Separated & Tips Removed
3 tbsps. Louisiana Brand Chicken Wing Seasoning
1 bag Cajun Injector® Chicken Fry Mix
1 cup Louisiana Brand Wildly Wicked Wing Sauce
2 cups Ranch Dressing
2 cups Blue Cheese Dressing
10 Celery Sticks

Method:

Preheat oil to 400°F in electric fryer, or 350°F in propane fryer. While oil heats up, season chicken pieces with wing seasoning. Once oil is hot, batter the wing pieces according to the directions on the bag. Fry at 350°F 10-15 minutes until golden brown, remove, and drain on paper towels. Toss chicken in wing sauce to coat evenly, for a less spicy wing cut the sauce with some melted butter. Serve with ranch and blue cheese dressing and celery sticks. The wings can also be grilled on charcoal or gas grill instead of frying cook for about 20-30 minutes.

Louisiana Wildly Wicked Boneless Buffalo Wings

Prep Time: 10 minutes

Cook Time: 7 minutes

Yield: 1 lb.

Ingredients:

Cajun Injector® Cottonseed Oil
1 lb. Boneless, Skinless Chicken Breast
1 bag Cajun Injector® Chicken Fry Mix
1/2 cup Louisiana Brand Wildly Wicked Wing Sauce
1/2 cup Ranch dressing
1/2 cup Blue Cheese dressing
10 Celery Stalks

Method:

Preheat oil to 400°F in electric fryer, or 350°F in propane fryer. Cut chicken breasts into chunks about 1" squares and batter according to the directions on the bag. Fry until golden brown, remove, and drain on paper towels. Toss chicken in wing sauce and coat evenly. Serve with ranch and blue cheese dressing and celery sticks.

Incredible Corn Dogs

Prep Time: 15 minutes

Cook Time: 3 minutes

Yield: 16 servings

Ingredients:

Cajun Injector® Cottonseed Oil
1-1/2 cups Cornmeal
1 cup All-purpose flour
1/2 cup Sugar
2 tsps. Baking powder
1-1/2 tsps. Salt
3/4 tsps. Black pepper
2 Large eggs
1/4 cup Cajun Injector® Creole Butter Recipe Marinade
3/4 cup Half-and-half
2 (12 oz.) Package hot dogs (regular size)
16 (10 oz.) wooden skewers
Creole mustard for dipping

Method:

Preheat oil to 400°F in electric fryer, or 350°F in propane fryer. Combine cornmeal, flour, sugar, baking powder, salt, and pepper; stir well with a whisk. In another bowl combine eggs, marinade, and half-and-half. Stir well. Combine cornmeal mixture and egg mixture. Mix until dry ingredients are moistened. Pat hot dogs dry with paper towels. Secure hot dogs onto wooden skewers. Dip into batter, coating all sides well. Fry a few hot dogs at a time for 3 minutes or until golden. Remove from hot oil and drain on paper towels. Serve warm with Creole mustard.

Copyright © 2003 The Ultimate Turkey Fryer Cookbook, Meredith Books

Fried Cornish Hens

Prep time: 15 minutes

Cook time: 16-20 minutes

Yield: 4 servings

Ingredients:

Cajun Injector® Cottonseed Oil
2 Whole Cornish Hens
6 oz. Cajun Injector® Creole Butter Recipe Marinade
Cajun Injector® Quick Shake® Cajun Shake® seasoning

Method:

Preheat oil to 400°F in electric fryer, or 350°F in propane fryer. Prepare Cornish hens while oil is heating. Remove giblets and rinse Cornish hens with warm water. Drain cavity completely. While oil is heating, inject Cornish hens using 1/2 ounce of marinade in each breast, 1/4 ounce into each leg and thigh.* Rub Cajun Injector Quick Shake Cajun Shake seasoning on the outside and inside of Cornish hens. Place Cornish hens in basket and lower slowly into oil. Fry for 10 minutes per pound of meat. Remove basket and place in a pan to drain excess oil.

Bite Size Crab Cakes

Prep Time: 20 minutes

Cook Time: 3-5 minutes

Yield: 24 1 inch patties

Ingredients:

Cajun Injector® Cottonseed Oil
1 lb. Fresh lump crab meat
1/2 cup Breadcrumbs
1 tbsp. Minced parsley
1/2 tsp. Salt
1/2 tsp. Pepper
1/4 cup Mayonnaise
1 cup Egg, lightly beaten
2 tsps. Worcestershire Sauce
1 tsp. Prepared mustard

Method:

Preheat oil to 400°F in electric fryer, or 350°F in propane fryer. Remove any shell pieces from crab meat. Lightly squeeze to drain excess moisture, transfer to dish, cover and chill until needed. Combine breadcrumbs, parsley, salt, and pepper; stir well with a whisk. Add mayonnaise, egg, Worcestershire sauce and mustard; stir well. Gently stir in crab meat. Shape mixture into 24 (1-inch) patties. Fry in 2 batches for 2 minutes or until golden. Remove from hot oil and drain on paper towels. Serve with cocktail sauce if desired.

Copyright © 2003 The Ultimate Turkey Fryer Cookbook, Meredith Books

Louisiana Cocktail Sauce

Prep time: 15 minutes

Cook time: n/a

Yield: 2 cups

Ingredients:

1 cup Tomato sauce
1/4 cup Ketchup
2 tbsps. Red wine vinegar
3 tbsps. Worcestershire sauce
1 tbsp. Horseradish
1/4 cup Chopped bell pepper
1/4 cup Chopped celery
1 tbsp. Diced garlic
Salt (to taste)
"Original" Louisiana Brand Hot Sauce to taste

Method:

In a large ceramic bowl, combine tomato sauce, ketchup, vinegar, Worcestershire sauce and horseradish. Using a wire whisk, blend until all ingredients are well incorporated. Add bell pepper, celery and garlic, and season to taste with salt and hot sauce. Continue to blend until all seasonings are evenly mixed throughout the sauce. Adjust seasonings to your taste should more sweetness or tartness be desired. Cover and refrigerate overnight for flavors to develop.

Stuffed Jalapeno Peppers

Prep Time: 30 minutes

Cook Time: 3-4 minutes

Yield: 24 stuffed jalapenos

Ingredients:

Cajun Injector® Cottonseed Oil
24 Fresh whole jalapeño peppers or 2 (12 ounce) jars whole jalapeno pepper,
drained
4 oz. Monterey Jack or cheddar cheese, cut into 24 (1-1/2 inch long) strips
1/2 cup All-purpose flour
1 tbsp. Cajun Injector® Quick Shake® Cajun Shake® seasoning
3/4 cup Buttermilk
Ranch-style dressing for dipping

Method:

Preheat oil to 400°F in electric fryer, or 350°F in propane fryer. Cut peppers length-wise down one side, leaving the other side intact. Remove seeds and membrane. Stuff each pepper with a piece of cheese. Combine flour and Cajun Injector Quick Shake Cajun Shake seasoning. Stir with a whisk. Slowly pour buttermilk into flour mixture while stirring. Stir until smooth. Dip stuffed peppers in batter, coating all sides well. Fry 6 to 8 peppers at a time for 2 minutes or until golden. Remove from hot oil and drain on paper towels. Serve warm with ranch-style dressing.

Copyright © 2003 The Ultimate Turkey Fryer Cookbook, Meredith Books

Fried Corn on the Cob

Prep Time: 10-15 minutes

Cook Time: 4 minutes

Yield: 12 servings

Ingredients:

Cajun Injector® Cottonseed Oil
1 package (12 half ears) frozen corn on the cob, thawed
Cajun Injector® Quick Shake® Cajun Shake® seasoning to taste

Method:

Preheat oil to 400°F in electric fryer, or 350°F in propane fryer. Fry corn in hot oil for 4 minutes, turning once. Remove and drain on paper towels. Sprinkle corn with Cajun Injector Quick Shake Cajun Shake seasoning.

Fried Potato Salad

Prep time: 30 minutes

Cook time: 5-10 minutes

Yield: 12 servings

Ingredients:

Cajun Injector® Cottonseed Oil
6 Large eggs
1 lb. Bacon
4 lbs. Red potatoes
Cajun Injector® Quick Shake® Cajun Shake® seasoning to taste
1-1/2 cups Mayonnaise
1/2 cup Dill pickle relish

Method:

Cover eggs with 1 inch cold water in a large pot. Place over medium-high heat. Bring to a boil. Cover and remove from heat. Let stand 15 to 17 minutes. Drain water. Run cold water over eggs until completely cool. Peel and chop eggs; set aside. Preheat oil to 400°F in electric fryer or 350°F in propane fryer. Separate bacon strips. Carefully lower each piece of bacon into hot oil; fry for 1 minute or until crisp. Remove from hot oil and drain on paper towels. Crumble; set aside. Scrub potatoes, and rinse with cold water. Cut into 1-inch cubes. Fry potatoes in batches for 5 minutes, or until tender and golden. Remove from hot oil and drain on paper towels. Place warm potatoes in a large bowl. Sprinkle with Cajun Injector Quick Shake Cajun Shake seasoning to taste and toss well. Add crumbled bacon, chopped eggs, mayonnaise, and relish; toss until potatoes are well coated.

Copyright © 2003 The Ultimate Turkey Fryer Cookbook, Meredith Books

Popcorn Shrimp

Prep Time: 20 minutes

Cook Time: 3-5 minutes

Yield: 6-8 servings

Ingredients:

Cajun Injector® Cottonseed Oil
1 lb. Cleaned crawfish tails or shrimp
1 tsp. Fresh thyme, chopped
1 tsp. Fresh basil, chopped
Salt and black pepper (to taste)
1 Egg
1 cup Water
1 cup Milk
3 tsps. "Original" Louisiana Brand Hot Sauce, divided
1 cup Cajun King® Cajun Fry Mix

Method:

Preheat oil to 400°F in electric fryer, or 350°F in propane fryer. Season crawfish or shrimp using thyme, basil, salt, black pepper, and 1 teaspoon of hot sauce. In a bowl, prepare an eggwash by combining egg, milk, water, and 2 teaspoons of hot sauce. Season eggwash to taste with salt and pepper. Place Cajun King Cajun Fry in a second bowl. Dip crawfish or shrimp in eggwash, then in Cajun Fry Mix. Deep fry until golden brown.

Chicken Fried Venison Steak

Prep Time: 10 minutes

Cook Time: 15 Minutes

Marinade Time: 1-2 hours

Yield: 4 servings

Ingredients:

- Cajun Injector® Cottonseed Oil
- 1 10 oz. Packet of Cajun Injector® Chicken Fry Mix
- 4 4 oz. Venison Cubed Steaks

Method:

Preheat oil to 400°F in electric fryer, or 350°F in propane fryer. Heat enough oil for deep frying to 350° F. Mix 6 tablespoons of Cajun Injector Chicken Fry Mix with 3/4 cup of water and mix until smooth. Dip steaks into batter then roll in remaining dry chicken mix until coated. Deep fry the coated steaks at 350° F until golden brown.

Boiled Crabs

Prep time: 15 minutes

Cook time: 40 minutes

Servings: 12 crabs

Ingredients:

- 1 Dozen Live Blue Crabs
- 3 tbsps. Cayenne Pepper
- 1/4 cup Table Salt
- 1/4 cup “Original” Louisiana Brand Hot Sauce
- 2 Lemons, Quartered
- 1 Onion, Halved
- 3/4 lb. Small Potatoes (about 2 inches in diameter)
- 1 Head of Garlic (not separated into cloves)
- 3 Ears of Corn, Shucked

Method:

Put 4 gallons of water in Cajun Injector® Fryer and set temperature to 400°F. While water is coming to a boil, in a deep sink, rinse crabs in 2 or 3 changes of water. Place crabs in fryer basket and set aside. Add cayenne, salt, hot sauce, lemons, and onions and boil 5 minutes. Add potatoes and garlic and boil until tender, about 15 minutes. Transfer potatoes and garlic with a large sieve to a platter and keep warm, covered with foil. Add corn to boiling water and cook until tender, about 5 minutes. Transfer corn with tongs to platter and keep warm, covered with foil. Return water to a boil. Add crabs. Return water to a boil and cook crabs until just cooked through, about 10 minutes. (To determine doneness, remove a claw and crack it with the handle of a dinner knife. Use knife to extract meat from claw). Remove basket from water, and hang on clip and let drain a few minutes. Serve.

Boiled Shrimp

Prep time: 15 minutes

Cook time: 30 minutes

Servings: 10 lbs. shrimp

Ingredients:

10 lbs. Fresh Shrimp Head on
3 tbsps. Cayenne Pepper
1/4 cup Table Salt
1/4 cup "Original" Louisiana Brand Hot Sauce
2 Lemons, Quartered
1 Onion ,Halved
3/4 lb. Small Potatoes (about 2 inches in diameter)
1 Head of Garlic (not separated into cloves)
3 Ears of Corn, Shucked

Method:

Put 4 gallons of water in Cajun Injector® Fryer and set temperature to 400°F. While water is boiling, rinse shrimp with cold water and place in fryer basket. When water is boiling add cayenne, salt, hot sauce, lemons, and onions and boil 5 minutes. Add potatoes and garlic, boil until tender, about 15 minutes. Transfer potatoes and garlic with a large sieve to a large platter and keep warm, covered with foil. Add corn to boiling water and cook until tender, about 5 minutes. Transfer corn with tongs to platter and keep warm, covered with foil. Return water to a boil. Place baskets with shrimp slowly into water return to a boil and cook shrimp until just cooked through, about 7 minutes or until pink. Remove basket from water and hang on clip and let drain a few minutes. Serve with favorite cocktail sauce.

Boiled Vegetables

Prep time: 15 minutes

Cook time: 20 minutes

Servings: N/A

Ingredients:

3 tbsps. Cayenne Pepper
1/4 cup Table Salt
1/4 cup "Original" Louisiana Brand Hot Sauce
2 Lemons, Quartered
4 Onions ,Halved
1 lb. Small Potatoes (about 2 inches in diameter)
1 Head of Garlic (not separated into cloves)
6 Ears of Corn, Shucked

Method:

Put 4 gallons of water in Cajun Injector® Fryer and set temperature to 400°F. While water is boiling, clean vegetables. When water is boiling add cayenne, salt, hot sauce, and onions. Boil for 5 minutes. Add potatoes and garlic; boil until tender, about 15 minutes. Transfer potatoes and garlic with a large sieve to a large platter and keep warm, cover with foil. Add corn to boiling water and cook until tender, about 5 minutes. Remove with tongs and serve with the rest of the vegetables.

Cajun Injector®

Friteuse • Chaudière • Marmite à vapeur

Manuel d'utilisation
Assemblage, Soins, Directives de sécurité
Outils nécessaires pour l'assemblage: Clé anglaise et tournevis cruciforme

Cet friteuse est destinée seulement pour l'usage à l'extérieur.

A travers la lecture de ce manuel d'utilisation, vous trouverez toutes les informations nécessaires à l'assemblage complet et à l'utilisation en toute sécurité de votre nouvelle friteuse à gaz. Avant d'assembler et d'utiliser cet appareil à gaz, veuillez lire et suivre toutes les précautions, suggestions et directives inscrites dans ce manuel. Une lecture approfondie du manuel d'utilisation, vous permettra d'éviter toutes erreurs qui peuvent s'avérer dangereuses et aussi d'améliorer en toute simplicité votre plaisir et votre expérience avec votre nouvelle friteuse.

Conserver et garder le manuel pour future références.



En suivant les directives et instructions dans ce manuel d'utilisation, vous aurez une expérience agréable et sans danger de cuisiner avec votre nouvelle friteuse à gaz. Pour tout aide supplémentaire et pour toutes pièces manquantes, n'hésitez pas de nous contacter à ce numéro vert: 1-800-229-9082.

- Certaines pièces ne sont pas incluses avec certains modèles de friteuses, veuillez à examiner l'emballage pour vous assurer de son contenu.
- Bonne de gaz LP non comprise.

Bruce Foods Corporation
P.O. Drawer 1030
New Iberia, LA 70562-1030 U.S.A.
www.cajuninjector.com

Si vous sentez le gaz :

- Fermer le robinet d'arrivée du gaz.
- Eteindre toutes flammes avec un extincteur.
- Si l'odeur persiste, rester au loin de l'appareil à gaz et téléphoner immédiatement à la caserne de sapeurs-pompiers dans votre localité.
- Veiller que cet appareil à gaz reste à une distance d'au moins 25 pieds (7.5 m) de tous produits liquides inflammables.
- Si un incendie se produit, rester au loin de votre appareil à gaz et contacter immédiatement la caserne de sapeurs-pompiers dans votre localité. Ne pas essayer d'éteindre un feu d'huile ou de graisse avec de l'eau.
- NE PAS utiliser cet appareil à moins de 10 pieds (3 m) d'une autre bonbonne de gaz.
- NE PAS laisser cet appareil sans surveillance.
- NE JAMAIS remplir la marmite au-dessus du niveau maximum de remplissage.
- NE PAS laisser la température de l'huile dépasser les 400°F (200°C). Si la température dépasse les 400°F (200°C) ou si l'huile commence à fumer fortement, fermer immédiatement le brûleur et l'arrivée de gaz.
- L'huile de cuisine chaude et beaucoup d'autres liquides à cuire peuvent rester dangereusement chauds pendant des périodes prolongées. Ne pas manipuler la friteuse à gaz avant que l'huile ait eu bien le temps de refroidir et qu'elle ait atteint une température inférieure à 115°F (45°C).
- Ne pas laisser la friteuse à gaz sans surveillance lorsque la flamme est vive. L'huile peut brûler rapidement et s'embraser lorsqu'elle atteint une température entre 550°F et 700°F (287°C et 370°C).
- Soyez très prudent quand vous êtes à proximité d'un appareil à gaz. Chuter ou trébucher près d'une friteuse à gaz ou prendre le pied dans un tuyau à gaz peut entraîner le débordement ou l'enflamment de l'huile ou l'éclaboussement d'eau bouillante ce qui peut causer des blessures sérieuses et des dégâts matériels importants.

**LE NON-RESPECT DE CES DIRECTIVES ET INSTRUCTIONS
OU AVERTISSEMENT PEUT CAUSER UN INCENDIE OU UNE
EXPLOSION QUI POURRAIENT ENTRAÎNER DES DÉGÂTS
MATÉRIELS, DES BLESSURES CORPORELLES, OU MÊME LA
MORT.**

CUIRE AVEC DE L'HUILE OU DE LA GRAISSE:

- NE PAS remplir la marmite d'eau, d'huile ou de graisse au-dessus du niveau maximum de remplissage. Suivre les instructions dans le manuel d'utilisation pour connaître les niveaux appropriés de remplissage d'huile, de graisse ou d'eau.
- Ne laissez pas la température de l'huile dépasser les 400°F (200°C). Si cela se produit, régler le bouton de commande du régulateur pour baisser la température. Si la température de l'huile continue à augmenter ou qu'elle commence à fumer, fermer IMMÉDIATEMENT le brûleur. Attendez que la température baisse à 350°F (177°C) et ensuite rallumer le brûleur en vérifiant que la température se maintienne au niveau désiré.
- Ne jamais laisser l'appareil à gaz sans surveillance pendant que vous chauffez de l'eau, de la graisse ou de l'huile, ou lorsque vous faites cuire des aliments. Après l'utilisation, ne laissez pas d'autres personnes ou animaux familiers près de l'appareil à gaz tandis qu'il est encore chaud. La température continuera à être élevée bien après que l'appareil à gaz soit arrêté. Laissez refroidir à 115°F (45°C) avant de procéder au nettoyage et au rangement.
- Des Aliments détremés ou pas complètement dégelés peuvent causer la graisse ou l'huile de déborder. Toujours décongeler complètement et essuyer avec un essuie-tout vos aliments avant de faire frire.
- Si la nourriture que vous voulez frire n'est pas complètement dégelée et qu'elle contient encore de la glace attention car cela peut causer des éclaboussures, des débordements et même un incendie.
- Utiliser le thermomètre fourni pour contrôler avec exactitude la température de l'huile ou de la graisse pendant la cuisson.
- Utiliser beaucoup de précautions quand vous placez la nourriture dans la marmite bouillante. Avec précautions surveiller qu'il n'y ait pas de débordements ou d'éclaboussures d'huile bouillante lorsque vous immergez la nourriture pour frire dans la friteuse à gaz.
- Quand vous faites bouillir de l'huile ou de la graisse ayez toujours à proximité et prêt à l'emploi un extincteur pour parer à toute éventualité d'incendie.

SI UN INCENDIE D'HUILE OU DE GRAISSE SE PRODUIT :

En cas d'incendie d'huile ou de graisse, n'essayez en aucun cas de l'éteindre avec de l'eau. Un extincteur de type BC ou ABC avec neige carbonique peut dans certains cas contenir l'incendie. Si possible :

1. Couper l'arrivée de gaz.
2. Muni d'un gant protecteur mettez le couvercle sur la marmite.

Si un incendie se produit (à l'extérieur de la marmite) suivre les indications suivantes;

1. Si des dégâts matériels sont à craindre, appeler la caserne des sapeurs pompiers
2. Essayer d'éteindre en utilisant l'extincteur à neige carbonique cité ci-dessus.
3. Couper l'arrivée du gaz si possible.

En cas de pluie, de neige, de verglas ou de grêle, ou toutes autres formes de précipitations, couvrez immédiatement la marmite de cuisson et fermez le brûleur et l'arrivée de gaz. NE PAS DEPLACER EN AUCUN CAS la marmite ou le socle de la friteuse à gaz.

- Ne pas utiliser cet appareil SUR ou SOUS un préau, abris de garage, tente, porte-à-faux, surplomb, balcon, terrasse ou plateforme.
- Ne jamais allumer la friteuse à gaz à l'intérieur; allumer seulement cet appareil à gaz au dehors. La friteuse à gaz ne doit jamais être utilisée à l'intérieur d'un bâtiment ou dans tous autres endroits fermés.
- Ne jamais placer un récipient à cuire vide sur l'appareil à gaz lorsqu'il est en fonction.
- Ne pas utiliser DANS ou SUR un camping-car et/ou sur un bateau.
- Ce produit n'est pas conçu pour être utilisé comme réchauffeur et il ne doit jamais être utilisé comme tel.
- Veiller que le tuyau d'alimentation de gaz reste bien à l'écart de la friteuse lorsqu'elle est chaude et en fonctionnement.
- Cet appareil à gaz doit toujours être placé à une distance d'au moins 10 pieds (3m) du mur, d'une rampe ou de toutes constructions en dur.
- Garder la zone de cuisson près de la friteuse à gaz vierge de tous débris, de combustibles ou tous objets pouvant s'enflammer.
- Utiliser cette friteuse à gaz uniquement sur une surface stable, à niveau et non-combustible comme de la brique, du béton ou un sol terreux. Ne pas utiliser la friteuse à gaz sur ou autour d'aucunes surfaces qui pourraient brûler ou fondre comme les parquets, plate-forme en bois, herbes sèches, feuilles, rampes en bois, surface en vinyle ou plastique. Les surfaces en asphalte doivent être évitées car elles peuvent également causer un risque d'incendie.
- Tous accessoires et ustensiles de cuisines qui ne sont pas fournis ou fabriqués par Cajun Injector® sont strictement déconseillés d'utiliser avec cette friteuse à gaz.
- Ne jamais utiliser la friteuse à gaz à des fins qui ne sont pas prévues dans son utilisation initial. Cette friteuse à gaz n'est pas conçue pour l'usage commercial.
- Ne laisser jamais les enfants et animaux familiers s'approcher à tout moment de la friteuse à gaz lorsqu'elle est en utilisation.
- Ne jamais laisser la friteuse à gaz sans surveillances.
- NE JAMAIS bouger la friteuse à gaz lorsqu'elle est en service. Laisser la friteuse refroidir à une température en dessous de 115°F (45°C) avant de la déplacer ou de la ranger.
- Ne portez pas des chaussures orteils à l'air mais des chaussures fermées pendant l'utilisation de la friteuse à gaz.
- Ne pas toucher les surfaces chaudes. Utiliser toujours des gants protecteurs lorsque vous retirez le couvercle ou le panier de la marmite.
- Avant d'allumer le brûleur, vérifier la direction du vent et que la bonbonne de gaz soit située du côté du vent en position droite et à une distance d'au moins 20 inches (0.5m) du brûleur.
- Utiliser uniquement une bonbonne de gaz de 20 livres (9 kg) maximum munie d'une bague protectrice.
- Placer toujours la friteuse à gaz Cajun Injector® dans un endroit à découvert et dans un rayon d'au moins 12 pieds (3.6 m).
- Ne laisser jamais aucunes parties de la friteuse à gaz toucher le tuyau d'alimentation à gaz pendant son utilisation.

- Procéder à l'essai d'étanchéité de gaz pour détecter toutes fuites de gaz sur toute la longueur du tuyau et aux points de raccordement avant chaque utilisation de la friteuse à gaz.
- Éviter de frapper ou de cogner la friteuse à gaz lors de son utilisation afin d'éviter tous débordements ou éclaboussements.
- Détacher toujours votre bonbonne de gaz du brûleur lorsque la friteuse n'est pas en service.
- Garder vos mains, cheveux et visage loin de la flamme du brûleur. **NE PAS** se pencher au-dessus du cuiseur quand vous allumez le brûleur. Cette friteuse à gaz a une flamme vive. Prendre soin que les cheveux et vêtements restent à l'écart lors du fonctionnement de l'appareil.
- Ne jamais attacher, détacher ou changer la bonbonne de gaz ou bouger ou ajuster le raccord pendant que le cuiseur est chaud ou en service.
- Ne jamais utiliser une bonbonne de gaz montrant des signes de craquelures, d'usure, d'érosion, de fuites, dégâts causés par le feu, rouille excessive ou tout autre forme de dommages externes visibles. La bonbonne de gaz peut être dangereuse et devrait être vérifiée avant l'utilisation par un fournisseur de gaz propane.
- Quand vous allumez votre friteuse à gaz, retirer toutes pièces inutiles du cuiseur et de son socle pour éviter une explosion qui pourrait être provoquée par une accumulation de gaz.
- Si le brûleur ne s'allume pas, fermer la vanne de commande du régulateur, et ensuite fermer l'arrivée de gaz. Attendre 5 minutes avant de procéder à un nouvel essai. Si le brûleur s'éteint pendant l'opération, tout d'abord fermer le régulateur et ensuite fermer la vanne de la bonbonne de gaz.
- Ne laissez personne avoir des activités autour de votre cuiseur pendant ou après son utilisation et ce jusqu'à ce que l'unité soit bien refroidi. Le cuiseur est chaud lors du fonctionnement et il restera chaud pendant un certain temps après son utilisation.
- Ne jamais faire tomber de la nourriture ou des accessoires dans des liquides chauds. Faites attention lorsque vous retirez de la nourriture de l'huile ou de l'eau bouillante. Accrochez le panier et laissez égoutter le liquide. Faire attention car le panier et son contenu sont très chaud et pourrait causer de sévères brûlures.
- Quand vous utilisez votre appareil faites très attention lorsque vous retirez le panier de la marmite de ne pas la faire tomber du socle du cuiseur.
- N'utiliser jamais d'ustensils de cuisines en verre, en plastique, ou en céramique avec votre appareil.
- Quand vous avez fini d'utiliser votre cuiseur, veiller toujours à fermer en premier la vanne de commande du régulateur et ensuite de fermer la vanne d'arrivée de gaz de la bonbonne.
- La consommation d'alcool, de médicaments ou de drogues avec ou sans ordonnance peut altérer votre capacité d'assembler ou d'utiliser la friteuse à gaz correctement. La consommation d'alcool, de médicaments ou de drogues avec ou sans ordonnance peut altérer votre capacité d'assembler ou d'utiliser correctement et sans risque cet appareil à gaz.
- Veillez que les orifices de ventilation de la bonbonne de gaz soient vierge de tous débris.

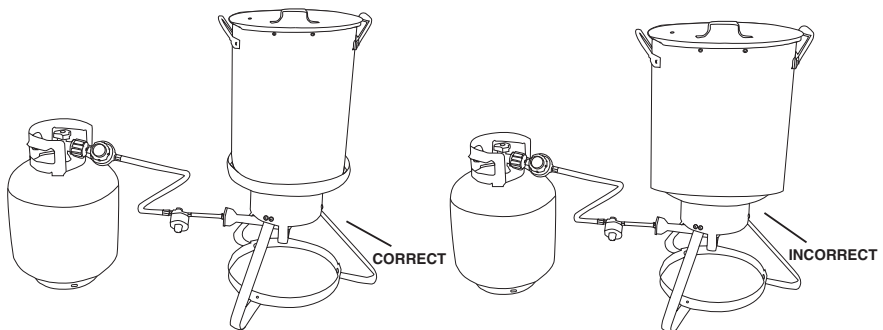

NE JAMAIS UTILISER UNE MARMITE OU UN FAIT-TOUT D'UNE CONTENANCE SUPÉRIEURE À 28.5 LITRES. LA MARMITE OU FAIT-TOUT DOIT ABSOLUMENT NE PAS DÉPASSER LA LIMITE DU CERCLE DE SÉCURITÉ DU CUISEUR.

Stockage, placement et remplissage de la bonbonne de gaz :

- Ne pas stocker une bonbonne de gaz de rechange dessous ou à proximité de l'appareil.
- Ne jamais remplir la bonbonne de gaz au delà de 80 pour cent de sa capacité. Les bonbonnes trop remplies peuvent laisser du gaz s'échapper.
- La soupape de sûreté de la bonbonne à gaz peut surchauffer et permettre au gaz de s'échapper et entraîner un violent incendie pouvant causer des blessures graves ou même la mort.
- Si vous sentez, entendez, ou voyez le gaz s'échapper, éloignez vous rapidement de la bonbonne de gaz, appeler immédiatement la caserne des sapeurs pompiers car un incendie pouvant entraîner la mort ou de graves blessures peut se produire à tout instant.
- Placer un bouchon de protection contre la poussière sur la sortie de la vanne de la bonbonne de gaz lorsque vous ne l'utilisez pas. Le bouchon de protection contre la poussière inclus doit être le seul bouchon de protection contre la poussière placé à la sortie de vanne de la bonbonne de gaz.
- D'autres bouchons de protection contre la poussière peuvent avoir des fuites.

Vérification de l'appareil et stockage de la bonbonne de gaz :

- Les bonbonnes de gaz doivent être stockées à l'extérieur, hors de portée des enfants et ne doivent jamais être stockées dans un bâtiment, dans un garage ou dans tout endroit fermé.
- Avant chaque utilisation vérifier que les écrous et boulons soient bien serrés et solidement fixés.
- Avant chaque utilisation examiner le tuyau de gaz pour s'assurer qu'il soit sans dommages apparents et qu'il ne montre pas de signes d'usures.
- Avant chaque utilisation faites un test d'eau savonneuse.

LISTE DES PIÈCES

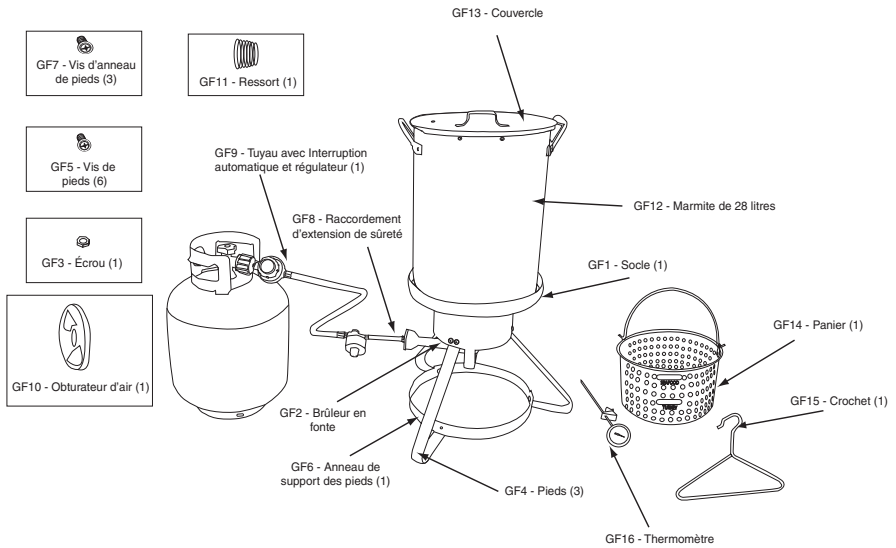

GF1 - Socle (1)

GF2 - Brûleur en fonte (1)

GF3 - Écrou (1)

GF4 - Pieds (3)

GF5 - Vis de pieds (6)

GF6 – Anneau de support des pieds (1)

GF7 - Vis d'anneau de pieds (3)

GF8 - Raccordement d'extension de sûreté (1)

GF9 - Tuyau avec Interruption automatique et régulateur (1)

GF10 - Obturateur d'air (1)

GF11 - Ressort (1)

GF12 – Marmite de 28 litres (1)

GF13 - Couvercle (1)

GF14 – Panier (1)

GF15 - Crochet (1)

GF16 - Thermomètre (1)

INSTRUCTIONS POUR L'ASSEMBLAGE

Outils nécessaires: Clé anglaise et tournevis cruciforme

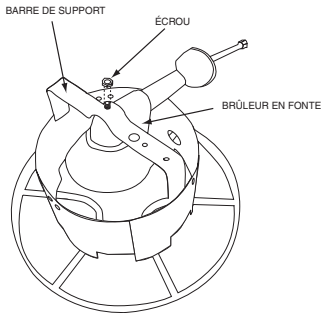

Étape 1 - Fixer le brûleur en fonte au socle

- Retourner complètement le socle et mettez le sur une surface plane. La barre de support du brûleur est celle qui est attachée aux deux côtés du bouclier.
- Retirer l'écrou du fond du brûleur en fonte.
- Partant du côté caché de la barre de soutien du brûleur, placer le brûleur en fonte dans la rainure au centre de la barre de soutien. L'avis sur le fond du brûleur en fonte doit être insérée dans le trou au centre de la rainure de la barre de soutien. Le brûleur en fonte doit être placé du même coté que le trou d'observation de la flamme.
- Attacher solidement la vis du brûleur en fonte à la barre de soutien du brûleur avec l'écrou fourni.

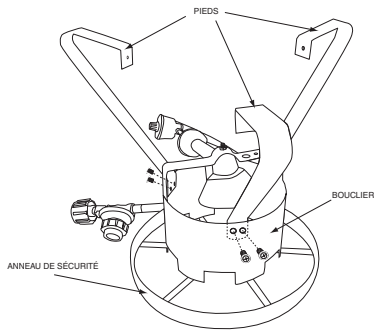

Étape 2 - Montage des pieds

- Repérer l'extrémité de chaque pieds contenant deux trous.
- Joindre chaque pieds à l'intérieur du bouclier en s'assurant que les deux trous dans chaque pieds soient alignés avec les deux trous du bouclier. Pour être en position correcte, les pieds doivent être attachés au bouclier et pointer vers l'extérieur. (voir illustration)
- Attacher solidement chaque pieds au bouclier avec deux vis par pieds. Les vis devraient être insérées de l'extérieur vers l'intérieur.

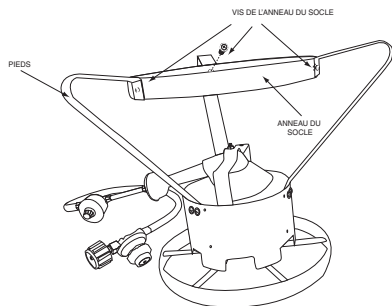

Étape 3 - Montage du socle rond en métal

- Insérer le cercle rond en métal entre chacun des trois pieds de sorte que chacun des trois trous du socle rond s'alignent parfaitement avec chaque trou à l'extrémité des pieds.
- Attacher solidement le socle rond en métal en insérant une vis dans chaque trou et en sérant bien. Les vis devraient être insérées de l'intérieur du socle rond vers l'extérieur.

INSTRUCTION POUR L'ASSEMBLAGE

Outils nécessaires : Clé anglaise et tournevis cruciforme

Étape 4 – Assemblage du tuyau

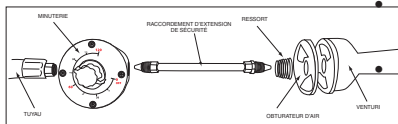

- Tourner le socle pour le mettre en position verticale et faites le reposer sur les pieds que vous venez d'installer.
- Placer l'obturateur d'air contre le venturi du brûleur de manière qu'il se positionne au dessus et serve de couvercle. Placer le ressort au-dessus du trou de l'obturateur d'air avec l'extrémité la plus large en contact avec l'obturateur d'air. Attacher le tuyau au bout de l'unité d'extension de sûreté (celui sans écrou pivotant) en branchant la minuterie avec l'extrémité du raccordement de l'unité d'extension de sûreté, faisant tourner dans le sens des aiguilles d'une montre jusqu'à ce que le tout soit bien attaché solidement. S'assurer que la minuterie avec arrêt automatique soit en position verticale pour faciliter sa lecture et son fonctionnement.
- Insérer le côté opposé de l'unité d'extension au centre de la partie la plus étroite du ressort en vissant l'obturateur d'air et le venturi du brûleur jusqu'à ce que le tout soit solidement fixé.

Étape 5 – Opération et connexion du régulateur de la bonbonne de gaz

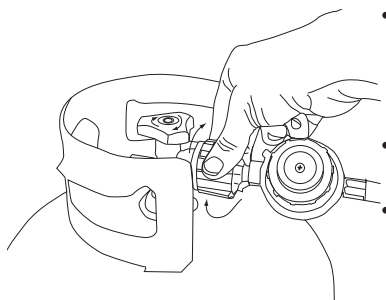

- Avant chaque utilisation, effectuer une inspection complète du tuyau ainsi que toutes les pièces qui y sont connectés. Si le tuyau montre tous signes d'usure ou de dommages, remplacer toutes les pièces nécessaires avant de continuer le fonctionnement.
- **AVERTISSEMENT** : Toutes flammes vives doivent être éteintes avant que le tuyau puisse être connecté à la bonbonne de gaz.
- S'assurer que la vanne de contrôle du régulateur soit fermer avant que le régulateur soit connecté à la bonbonne de gaz. Connecter le régulateur à la bonbonne de gaz en tournant le régulateur dans le sens des aiguilles d'une montre sur la partie ouverte et filetée de la bonbonne jusqu'à ce que le régulateur soit solidement attaché.
- Tourner doucement la vanne du régulateur dans le sens des aiguilles d'une montre allumera la flamme et augmentera progressivement l'intensité de la flamme. Tourner doucement la vanne du régulateur dans le sens contraire des aiguilles d'une montre diminuera progressivement la l'intensité de la flamme jusqu'à son extinction.

Étape 6 – Test de fuite de gaz

- Seulement du gaz propane doit être utilisé pour l'utilisation de ce brûleur. Ne jamais employer le gaz naturel. Le brûleur ne fonctionnera pas correctement si vous n'utilisez pas le type de gaz recommandé.
- A chaque fois que le brûleur est attaché à une bonbonne de gaz, vous devez procéder au test de fuite de gaz.
- Toutes choses qui peuvent facilement s'embraser comme les allumettes, les briquets, étincelles et cigarettes allumées doivent être absolument mis à l'écart du brûleur lorsque vous procédez au test de fuite de gaz. Ne jamais employer une flamme pour déterminer des fuites de gaz.
- Ne jamais procéder au test de fuite de gaz à l'intérieur d'un bâtiment ou dans tout endroit fermé. Le test doit toujours être fait à l'extérieur et dans un endroit ventilé.
- Tous les ustensils de cuisines doivent être retirés du dessus du cuiseur avant de procéder au test de fuite de gaz.

PROCÉDURE A SUIVRE:

- Retirez tous les ustensils de cuisine du dessus du cuiseur.
- Tourner la vanne de la bonbonne de gaz dans le sens contraire des aiguilles d'une montre jusqu'à ce qu'elle soit fermée. Tourner la vanne de contrôle du régulateur dans le sens contraire des aiguilles d'une montre jusqu'à ce qu'elle soit fermée.
- Combiner 3 parts d'eau avec 1 part de savon liquide. Mélanger bien. Appliquer l'eau savonneuse sur la vanne de la bonbonne de gaz, sur la vanne de contrôle du régulateur et sur toute la longueur du tuyau jusqu'au brûleur.
- Tourner lentement la vanne de la bonbonne de gaz dans le sens des aiguilles d'une montre jusqu'à ce qu'elle soit ouverte et inspecter pour détecter des bulles de savon. **NE JAMAIS LAISSER LA VANNE DE LA BONBONNE DE GAZ OUVERTE PENDANT UNE DURÉE SUPÉRIEURE À 12 SECONDES.** Si des bulles de savon apparaissent, tourner la vanne de la bonbonne de gaz dans le sens contraire des aiguilles d'une montre jusqu'à ce qu'elle soit fermée. Pour fixer la fuite, enlever et remplacer le raccordement et replacer le correctement. Si la solution savonneuse rend les parties trop glissantes et vous empêche d'obtenir un maintien ferme, nettoyer les parties avec un tissu humide pour éliminer le savon. Une fois le problème corrigé, réappliquer la solution de savon et répéter le test.
- Quand la vanne de la bonbonne de gaz a passé le test de fuite de gaz, tourner la vanne de contrôle du régulateur dans le sens des aiguilles d'une montre jusqu'à ce qu'elle soit ouverte. Ensuite vérifier la vanne de contrôle du régulateur, le tuyau et le brûleur pour toutes traces de bulles de savon.
- **NE JAMAIS LAISSER LA VANNE DE LA BONBONNE DE GAZ OUVERTE PENDANT UNE DURÉE SUPÉRIEURE À 12 SECONDES.** Si des bulles de savon apparaissent c'est un signe qu'il y a une fuite de gaz dans la zone inspectée. S'il y a une fuite dans une zone de connection, cela peut être réparé en resserrant le raccord. S'il y a une fuite dans le tuyau, cela peut être réparé en changeant le tuyau. Le tuyau doit être changé avant que vous puissiez continuer à utiliser l'appareil. **NE PAS ESSAYER DE REPARER LE TUYAU.** Une fois que le test est accompli et sans fuites, vous pouvez poursuivre l'utilisation de votre brûleur mais vous devez attendre cinq minutes au minimum avant de mettre en marche le brûleur.
- La bonbonne de gaz n'est pas incluse avec l'appareil.
- Ne jamais utiliser une bonbonne de gaz sans bague protectrice de taille supérieure à 20 livres (9 Kg).
- Si des bulles de savon persistent après avoir fait le test de fuite de gaz, arrêtez immédiatement l'utilisation. Pour toute assistance et aide avec ce mal fonctionnement, appelez votre revendeur de propane ou Bruce Foods Corporation au 1-800-229-9082.

Étape 7 - Allumage du brûleur

- S'assurer que la vanne de contrôle du régulateur soit fermer.
- Tourner lentement la vanne de la bonbonne de gaz dans le sens des aiguilles d'une montre jusqu'à ce qu'elle soit ouverte.
- Pour votre sécurité, il est conseillé d'utiliser une allumette pour gril ou un briquet spécial pour gril. Allumer le brûleur en introduisant une flamme sous le bouclier à vent du brûleur.
- Tourner lentement la vanne de contrôle du régulateur jusqu'à ce qu'elle soit ouverte et que le brûleur s'allume. Si cela prend plus de cinq secondes pour que le brûleur s'allume, fermer la vanne de contrôle du régulateur et fermer la vanne de la bonbonne de gaz. Répéter ensuite le procédé d'allumage.
- **DANS LE CAS OÙ LA FLAMME S'ÉTEIND, NE PAS RALLUMER LE BRÛLEUR PENDANT CINQ MINUTES. CECI PERMET DE DONNER ASSEZ DE TEMPS AUX VAPEURS RESTANTES DE S'ÉVACUER.**
- Aussi-tôt que la flamme est allumée, tourner la vanne de contrôle du régulateur dans le sens des aiguilles d'une montre jusqu'à ce que la flamme s'intensifie. Tourner l'obturateur d'air, en permettant à plus ou moins d'air d'entrer dans le brûleur jusqu'à ce que la flamme devienne bleue. Une fois que la flamme atteint sa couleur appropriée, ajustez la flamme avec la vanne de contrôle du régulateur pour atteindre le niveau d'intensité désiré.
- Remplissez la marmite jusqu'au niveau maximum de remplissage. Ne jamais remplir la marmite au-dessus de l'indicateur de niveau maximum de remplissage pour éviter tous risque de brûlure ou d'accidents causés par le débordement d'huile bouillante.
- **NE PAS PLACER UNE MARMITE VIDE SUR UN BRÛLEUR ALLUMÉ. CECI PEUT CAUSER DES DÉGATS SÉRIEUX À LA MARMITE.**
- Tourner la vanne de contrôle du régulateur dans le sens des aiguilles d'une montre et dans le sens contraire des aiguilles d'une montre amènera le contenu de votre marmite à la température désirée. Il se peut que la graisse ou l'huile s'embrace quand la température atteint 400°F (204°C) ou plus, c'est pourquoi il est extrêmement recommandé de ne pas laisser la température aller au dessus des 350°F (176°C). Pour vous assurer que la température reste constante pendant l'utilisation de votre brûleur il est conseillé que vous utilisiez un thermomètre pendant toute la durée de fonctionnement de votre appareil.
- **SI LE BRÛLEUR COMMENCE À FUMER, FERMER LE IMMÉDIATEMENT.**
- Une fois que vous avez fini d'utiliser l'appareil, éteignez le en tournant en premier la vanne de contrôle du régulateur dans le sens contraire des aiguilles d'une montre et ensuite tourner la vanne de la bonbonne de gaz dans le sens contraire des aiguilles d'une montre. Toutes les parties de l'appareil, la marmite et le contenu restant doivent avoir suffisamment de temps pour refroidir avant d'être touchées et rangeés.
- **NE RÉDUISEZ PAS LA FLAMME POUR MAINTENIR L'HUILE CHAUDE POUR UNE SECONDE UTILISATION. LA TEMPÉRATURE CONTINUERA À AUGMENTER ET L'HUILE POURRAIT MÊME S'EMBRASER SI LE BRÛLEUR N'EST PAS COMPLÈTEMENT FERMÉ.**

Étape 8 – Système d'écoulement rapide

- Repérer les deux crochets à l'intérieur de la marmite non loin du rebord supérieur. Ces deux crochets sont les crochets du système d'écoulement rapide.
- Deux trous de formes ovales sont situés sur le panier : Au dessus d'un des trous il est marqué « dinde » et sur l'autre il est marqué « fruits de mer ».
- Le panier peut se pendre sur les crochets en insérant les crochets d'écoulement rapide à travers l'un des deux trous de forme ovale dans le panier.
- Quand le temps de cuisson désiré s'est écoulé, vous êtes prêt à vidanger l'excès de liquide de la nourriture qui est dans le panier. Tout en portant des gants protecteurs, utiliser le crochet en métal fourni pour soulever le panier par le manche pivotant en métal. Selon le type de nourriture que vous voulez cuire, suspendez le panier sur un des crochets d'écoulement rapide en insérant les deux crochets dans le trou marqué « dinde » ou « fruits de mer ».
- Laisser le temps à la nourriture de s'égoutter pendant au moins quelques minutes ou jusqu'à ce que vous pouvez déterminer que l'excès d'huile a été retourné dans la marmite. **NE JAMAIS** enlever le panier de la marmite à frire sans laisser le temps nécessaire à la nourriture de s'écouler.
- Le système d'écoulement rapide peut également être utilisé pour cuire des fruits de mer à la vapeur. Dans ce cas, ajouter 6 pouces (15 cm) d'eau dans le fond de la marmite, suspendre le panier sur le crochet d'écoulement rapide marqué « fruits de mer, » et fermer la marmite avec le couvercle. Le temps de cuisson variera selon le type de nourriture que vous cuisinez à la vapeur.

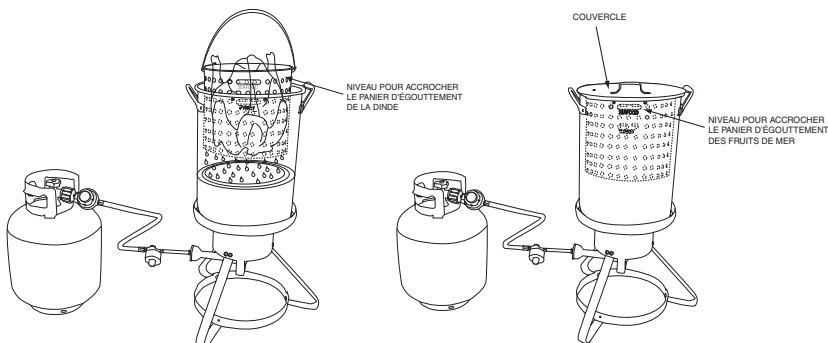

Étape 9 – Fonctionnement de la soupape de vidage (sur certains modèles seulement)

- La soupape de vidage située près du bord inférieur de la marmite à frire, vous permet de vidanger facilement et sans risques l'eau ou l'huile qui se trouve dans la marmite.
- **ASSUREZ-VOUS QUE LE LIQUIDE À L'INTÉRIEUR DE LA MARMITE AIE ATTEINT UNE TEMPÉRATURE INFÉRIEURE À 100°F (37°C) AVANT DE VIDANGER.**
- Le liquide doit tout d'abord être vidé dans un récipient avant d'être jeté.
- Placer le récipient de votre choix directement en dessous du bec verseur de la soupape de vidage; assurez-vous bien que le récipient et la marmite sont stables et pas facilement inclinables.
- Tourner le bouton noir sur le dessus du bec de vidage de 180° ou jusqu'à un débit constant de liquide sorte de la soupape de vidage et tombe dans le récipient.
- Fermer la vanne en tournant le bouton dans le sens inverse et ceci seulement une fois que tout le liquide a eu le temps de s'écouler.
- Certaines huiles à frire peuvent être réutilisées dans une période de quelques jours après avoir été utilisées. Beaucoup de personnes considèrent la soupape de vidage comme une option très utile pour facilement remettre l'huile à frire dans sa bouteille d'origine pour ré-utiliser à une date ultérieure.

Frire des nourritures décongelées
(L'huile peut prendre jusqu'à 55 minutes pour atteindre la température désirée)

Nourriture	Quantité maximum	Température	Durée
Pommes frites	3 livres. (1.36 kilogramme)	400°F (204°C)	5-7 minutes
Poulet frit	8 morceaux	350°F (177°C)	14-18 minutes
Champignons	2 livres. (0.91 kilogramme)	325°F (163°C)	10-12 minutes
Filets de poissons	2 livres. (0.91 kilogramme)	400°F (204°C)	6-8 minutes
Dinde entière	10-14 livres. (4.5-6.4 kilogrammes)	400°F (204°C)	3 mn par livre. (0.45 kilogramme) plus 5 minutes
Ailes de poulet frits	3 livres. (1.36 kilogrammes)	400°F (204°C)	8-10 minutes

Frire des aliments surgelés
(Se référer préalablement aux instructions sur le conditionnement des aliments)

Gombo frit	3 livres. (1.36 kilogramme)	400°F (204°C)	5-7 minutes
Pépites de poulet	2 livres. (0.91 kilogramme)	375°F (191°C)	7-8 minutes
Champignons	2 livres. (0.91 kilogramme)	375°F (191°C)	8-9 minutes
Bâtonnets de poissons	2 livres. (0.91 kilogramme)	375°F (191°C)	6-7 minutes
Saucisse pané sur bâtonnet	10 livres. (4.5 kilogrammes)	375°F (191°C)	Voir l'emballage
Bâtonnet de fromage	2 livres. (0.91 kilogramme)	325°F (163°C)	Voir l'emballage

Bouillir des nourritures décongelées

Maïs en épis	15-20 épis	250°F (121°C)	5-8 minutes
Crevette	10 livres. (4.5 kilogrammes)	250°F (121°C)	3-4 minutes ou jusqu'à ce qu'elles soient roses
Pommes de terre rouges	10 livres. (4.5 kilogrammes)	250°F (121°C)	25 minutes
Oeufs	1 douzaine	250°F (121°C)	10 minutes
coquille de pâtes	3 livres. (1.36 kilogramme)	250°F (121°C)	Jusqu'à ce qu'elle soit tendre
Hot-Dogs	50	250°F (121°C)	2-3 minutes

Nourritures cuites à la vapeur
(Se référer préalablement aux directives sur le paquet d'emballage des aliments)

Pattes de crab royal	3 livres. (1.36 kilogramme)	250°F (121°C)	5-8 minutes
Palourdes/moules	10 livres. (4.5 kilogrammes)	250°F (121°C)	5-7 minutes ou jusqu'à ce qu'elles soient ouvertes
Courge jaune aux piments rouges	2 livres. (0.91 kilogramme)	250°F (121°C)	cuire à la vapeur jusqu'à ce qu'elles soient tendre
Crab bleu	10	250°F (121°C)	6-10 minutes
Homar	1-4	250°F (121°C)	10-12 minutes

Ne jamais mettre de la volaille congelée dans de l'huile bouillante. Employer extrême prudence quand vous faites frire des aliments surgelés. Ne pas remplir la marmite au dessus du niveau maximum de remplissage et ne pas dépasser la quantité maximale de nourriture dans le panier. Un débordement pourrait entraîner de graves blessures. Faire descendre le panier lentement dans l'huile bouillante et couvrir avec le couvercle. Porter toujours des gants de cuisine protecteurs. Essuyer toutes traces d'humidité de la nourriture que vous êtes sur le point de frire.